

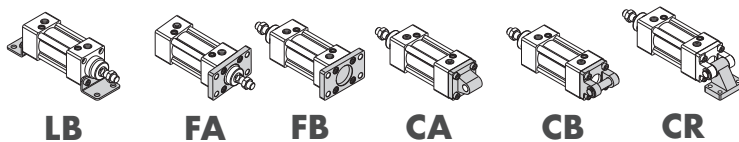

Articulaciones para Cilindro



Tipos de Montaje



Fuerza de Trabajo

$$F = P \times A$$

Fuerza
(Empuje del Cilindro) N

=

Presión de Aire
MPa

X

Área de Cilindro
mm²

Unidad: Newton(N)

Ø Cilindro (mm)	Ø Vástago (mm)	Tipo de Accionamiento	Área de Presión (mm ²)	Presión de Trabajo (MPa)									
				0.1	0.2	0.3	0.4	0.5	0.6	0.7	0.8	0.9	
32	12	Doble Efecto	Avance	804	80.4	160.8	241.2	321.6	402.0	482.4	562.8	643.2	723.6
		Retorno	690	69.0	138.0	207.0	276.0	345.0	414.0	483.0	552.0	621.0	
40	16	Doble Efecto	Avance	1256	125.6	251.2	376.8	502.4	628.0	753.6	879.2	1002.4	1130.4
		Retorno	1055	105.5	211.0	316.5	422.0	527.5	633.0	738.5	844.0	949.5	
50	20	Doble Efecto	Avance	1963	196.3	392.6	588.9	785.2	981.5	1177.8	1374.1	1570.4	1766.7
		Retorno	1649	164.9	329.8	494.7	659.6	824.5	989.4	1154.3	1399.2	1484.1	
63	20	Doble Efecto	Avance	3117	311.7	623.4	935.1	1246.8	1558.5	1870.2	2181.9	2493.6	2805.3
		Retorno	2803	280.3	560.6	840.9	1121.2	1401.5	1681.8	1962.1	2242.4	2522.7	
80	25	Doble Efecto	Avance	5026	502.6	1005.2	1507.8	2010.4	2513.0	3015.6	3518.2	4020.8	4523.4
		Retorno	4536	453.6	907.2	1360.8	1814.4	2268.0	2721.6	3175.2	3628.8	4082.4	
100	25	Doble Efecto	Avance	7853	785.3	1570.6	2355.9	3141.2	3926.5	4711.8	5497.1	6282.4	7067.7
		Retorno	7362	736.2	1472.4	2208.6	2948.6	3681.0	4417.2	5153.4	5889.6	6625.8	
125	32	Doble Efecto	Avance	12272	1227.2	2454.4	3681.6	4908.8	6136.0	7363.2	8590.4	9817.6	11044.8
		Retorno	11468	1146.8	2293.6	3440.4	4587.2	5734.0	6880.8	8027.6	9174.4	10321.2	



Especificaciones SE

Simbología

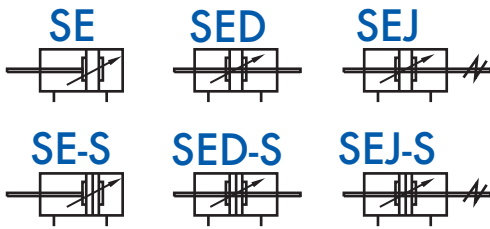

Ø Cilindro (mm)	32	40	50	63	80	100	125
Tipo de Accionamiento	Doble Efecto						
Fluido	Aire (filtrado a 40 µm)						
Tipo de Montaje	SE	Básico: FA FB CA CB CR LB TC FTC TCM1 TCM2					
	SED SEJ	Básico: FA LB TC FTC TCM1 TCM2					
Presión de Trabajo	0.15 - 1.0 MPa (22 - 145 psi) (1.5 - 10.0 bar)						
Presión de Prueba	1.5 MPa (215 psi) (15 bar)						
Temperatura °C	-20 a 70						
Velocidad mm/s	30 - 800						30 - 500
Tolerancia de Carrera	0 - 250 ^{+1.0} ₀		251 - 1000 ^{+1.5} ₀		1001 - 1500 ^{+2.0} ₀		
Tipo de Amortiguación	Amortiguación Variable						
Carrera de amortiguación ajustable	27	30	36	40			
Tamaño de Puerto	1/8"	1/4"	3/8"	1/2"			
TPU Sellos Normal -5 a 80 °C							
NBR Sellos Viton Maximo 180 °C (Recomendado Hasta 120 °C)							

Cómo Ordenar

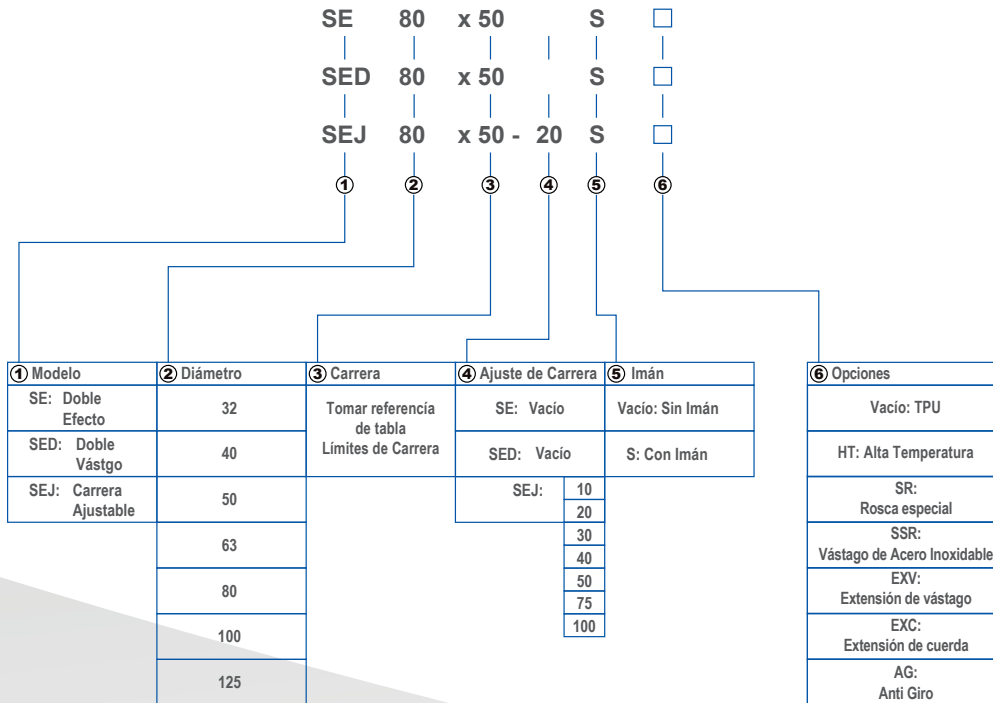

Material Vástago
Acero al Carbón 1045 20 micras de cromo
Acero Inoxidable 304 20 micras de cromo

Tipo de Montaje	
SE:	Vacío
	LB
	FA
	FB
	CA
	CB
	CR
SED SEJ:	Vacío
	LB
	FA
	FTC
	TC

Límites de Carrera

Ø Cilindro (mm)	Carrera Estándar (mm)																			Máxima Carrera Estándar	Máxima Carrera		
	25	50	75	80	100	125	150	160	175	200	250	300	350	400	450	500	600	700	800			900	1000
32	25	50	75	80	100	125	150	160	175	200	250	300	350	400	450	500						1000	1800
40	25	50	75	80	100	125	150	160	175	200	250	300	350	400	450	500	600	700	800			1200	1800
50	25	50	75	80	100	125	150	160	175	200	250	300	350	400	450	500	600	700	800	900	1000	1200	1800
63	25	50	75	80	100	125	150	160	175	200	250	300	350	400	450	500	600	700	800	900	1000	1500	1800
80	25	50	75	80	100	125	150	160	175	200	250	300	350	400	450	500	600	700	800	900	1000	1500	1800
100	25	50	75	80	100	125	150	160	175	200	250	300	350	400	450	500	600	700	800	900	1000	1500	1800
125	25	50	75	80	100	125	150	160	175	200	250	300	350	400	450	500	600	700	800	900	1000	1500	1800

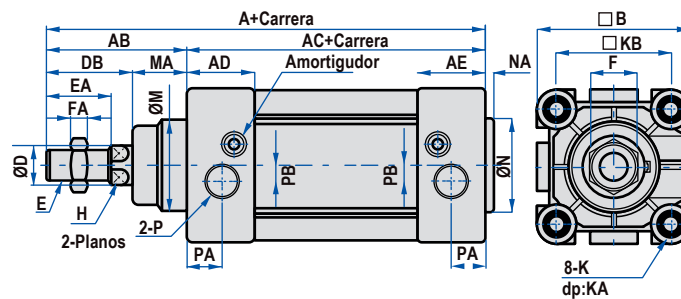

Dimensiones SE

Ø Cilindro (mm)	A	AB	AC	AD	AE	B	D	DA	E	EA	F	FA	H	K	KA	KB	M	MA	NA	N	P	PA	PB
32	142	48	94	27.5	27.5	46.5	12	29	M10 x 1.25	22	17	6	10	M6 x 1	16	32.5	30	19	3	30	1/8"	13.5	6
40	159	54	105	32	32	54	16	33	M12 x 1.25	24	17	7	13	M6 x 1	17	38	35	21	3.5	35	1/4"	17.5	6
50	175	69	106	31	31	64	20	42	M16 x 1.5	32	23	8	17	M8 x 1.25	17	46.5	40	27	3.5	40	1/4"	14	8
63	190	69	121	33	33	75	20	42	M16 x 1.5	32	23	8	17	M8 x 1.25	17	56.5	45	27	4	45	3/8"	17	8
80	214	86	128	33	33	93	25	53	M20 x 1.5	40	26	10	22	M10 x 1.5	19	72	45	33	4	45	3/8"	16.5	8
100	229	91	138	37	37	110	25	55	M20 x 1.5	40	26	10	22	M10 x 1.5	19	89	55	36	4	55	1/2"	19.5	10
125	279	119	160	46	46	134	32	74	M27 x 2	54	41	13.5	27	M12 x 1.75	22	110	60	45	4	60	1/2"	23	11

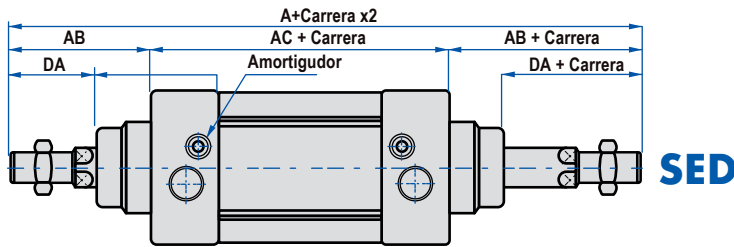

Dimensiones SED Doble Vástago SEJ Ajuste de Carrera

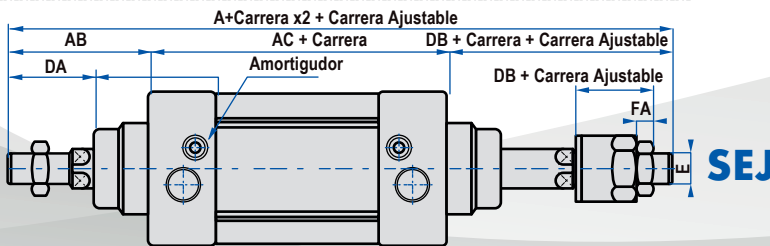

Ø Cilindro (mm)	A		AB	AC	DA	DB	E	FA
	SED	SEJ						
32	190	188	48	94	29	27	M10X1.25	6
40	213	208	54	105	33	28	M12X1.25	7
50	244	231	69	106	42	29	M16X1.5	8
63	259	246	69	121	42	29	M16X1.5	8
80	300	282.5	86	128	53	35.5	M20X1.5	10
100	320	300.5	91	138	55	35.5	M20X1.5	10
125	398	366.5	119	160	74	42.5	M27X2.0	13.5

Montajes

Códigos de Accesorios Montajes

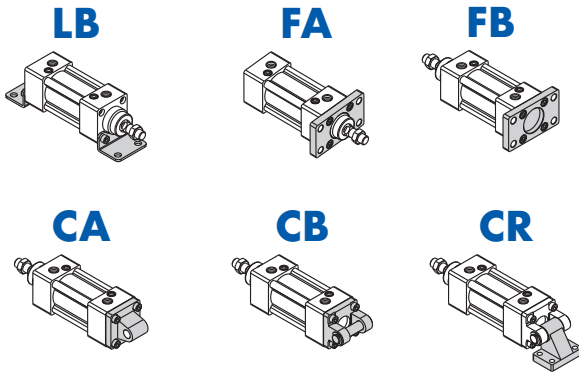

Ø Cilindro (mm)	Accesorios de Montaje				
	LB	FA / FB	CA	CB	CR
32	F-SI32LB	F-SI32FA	F-SE32CA	F-SE32CB	F-SI32CR
40	F-SI40LB	F-SI40FA	F-SE40CA	F-SE40CB	F-SI40CR
50	F-SI50LB	F-SI50FA	F-SE50CA	F-SE50CB	F-SI50CR
63	F-SI63LB	F-SI63FA	F-SE63CA	F-SE63CB	F-SI63CR
80	F-SI80LB	F-SI80FA	F-SE80CA	F-SE80CB	F-SI80CR
100	F-SI100LB	F-SI100FA	F-SE100CA	F-SE100CB	F-SI100CR
125	F-SI125LB	F-SI125FA	F-SE125CA	F-SE125CB	F-SI125CR

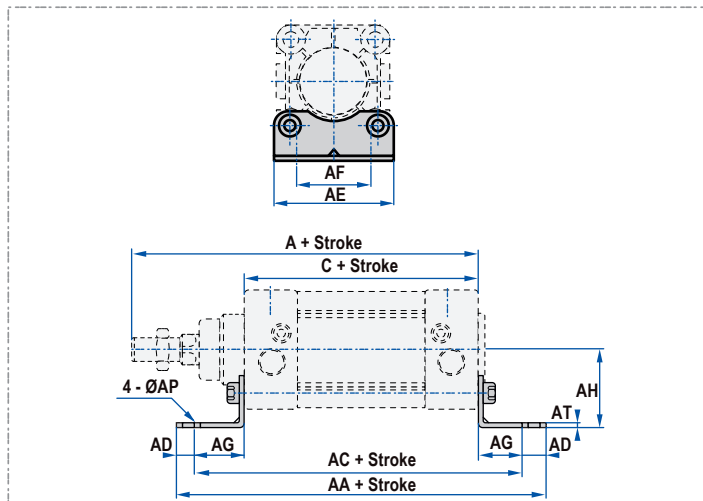

Dimensiones LB

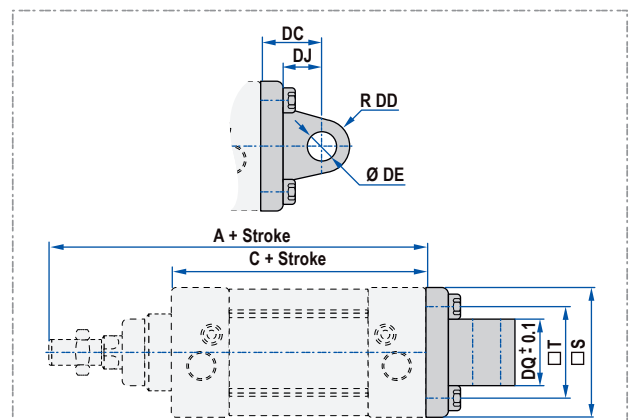

Dimensiones CA

Ø Cilindro (mm)	A	C	AA	AC	AD	AE	AF	AG	AH	AP	AT
32	142	94	158	142	8	47	32	24	32	7	3
40	159	105	179	161	9	53	36	28	36	9	3
50	175	106	190	170	10	65	45	32	45	9	3
63	190	121	209	185	12	75	50	32	50	9	3
80	214	128	248	210	19	95	63	41	63	12.5	4
100	229	138	258	220	19	115	75	41	71	14.5	4
125	279	160	290	250	20	140	90	45	90	16.5	8

Ø Cilindro (mm)	A	C	S	T	DC	DD	DE	DJ	DQ
32	142	94	47	32.5	22	9	10	13	25.8
40	159	105	54	38	25	10.5	12	16	27.8
50	175	106	64	46.5	27	11	12	17	31.7
63	190	121	75	56.5	32	13.5	16	22	39.7
80	214	128	93	72	36	14.5	16	22	49.7
100	229	138	110	89	41	17	20	27	59.7
125	279	160	134	110	50	22	25	33	69.7

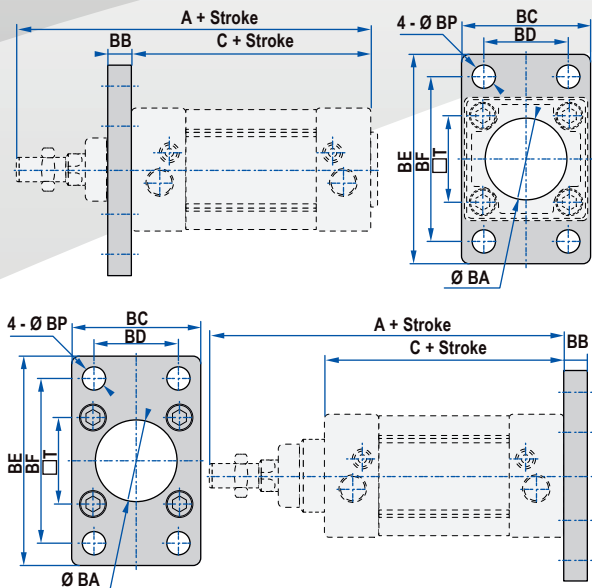

Dimensiones FA / FB

Ø Cilindro (mm)	A	C	BA	BB	BC	BD	BE	BF	BP	T
32	142	94	30.5	10	47	32	80	64	7	32.5
40	159	105	35.5	10	53	36	90	72	9	38
50	175	106	40.5	12	65	45	108	90	9	46.5
63	190	121	45.5	12	75	50	118	100	9	56.5
80	214	128	45.5	16	95	63	150	126	12.5	72
100	229	138	55.5	16	115	75	176	150	14.5	89
125	279	160	60.5	20	139	90	218	180	16.5	110

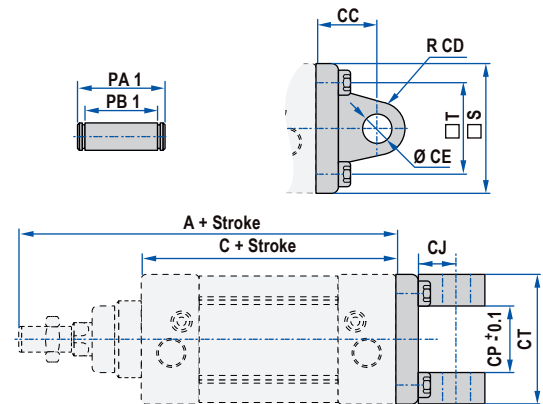

Dimensiones CB

Ø Cilindro (mm)	A	C	CC	CD	CE	CJ	CP	CT	PA1	PB1	S	T
32	142	94	22	10.5	10	13	26	45	51	45.5	46.5	32.5
40	159	105	25	12	12	16	28	52	59	52.5	54	38
50	175	106	27	12	12	17	32	60	67	60.5	64	46.5
63	190	121	32	15	16	22	40	70	77	70.5	75	56.5
80	214	128	36	15.5	16	22	50	90	97	90.5	93	72
100	229	138	41	20	20	27	60	110	119	110.5	110	89
125	279	160	50	24	25	33	70	130	139	130.5	134	110

Dimensiones CR

Ø Cilindro (mm)	A	AA	B	C	CC	CD	CJ	D	E	F	G	H	I	K	L
32	142	32	26	94	10	49	10	21	18	30	8	38	50	6.5	10.5
40	159	36	28	105	12	55	12	24	22	34	10	41	53	6.5	10.5
50	175	45	32	106	12	67	13	33	30	44	12	50	64	9	14
63	190	50	40	121	16	76	17	37	35	49	12	52	66	9	14
80	214	63	50	128	16	92.5	19.5	47	40	59	14	66	85	11	17
100	229	71	60	138	20	105.5	22.5	55	50	69	15	76	95	11	17
125	279	90	70	160	25	134	29	70	60	88	20	94	122	13.5	20

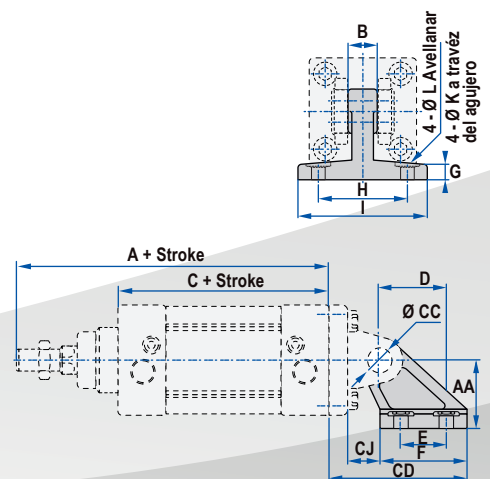

Articulaciones

Códigos de Accesorios Articulaciones para Cilindros



Horquilla I Macho



Horquilla Y Hembra



Junta Flotante



Rótula

Ø Cilindro (mm)	Nudillos				Sensor CMSE	Switch DMSE
	I	Y	F	U		
32	F-M10x125I	F-M10x125Y	F-M10x125F	F-M10x125U		
40	F-M12x125I	F-M12x125Y	F-M12x125F	F-M12x125U		
50	F-M16x150I	F-M16x150Y	F-M16x150F	F-M16x150U		
63	F-M16x150I	F-M16x150Y	F-M16x150F	F-M16x150U	CMSE	DMSE
80	F-M20x150I	F-M20x150Y	F-M20x150F	F-M20x150U		
100	F-M20x150I	F-M20x150Y	F-M20x150F	F-M20x150U		
125	F-M27x200I	F-M27x200Y	F-M27x200F	F-M27x200U		

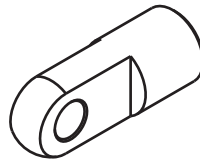

Horquilla I Macho

Cómo Ordenar

F M16 x 150 I

① Código Accesorio	② Rosca de Tornillo	③ Paso de Rosca	④ Código
	M10	125: 1.25mm	I: Horquilla I Macho
	M12		
	M16	150: 1.5mm	
	M20		
	M27		
	M36	200: 2.0mm	
	M42		

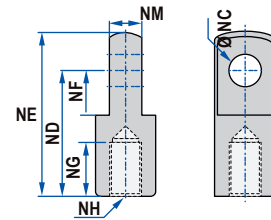

Dimensiones

Item	NC	ND	NE	NF	NG	NH	NM
F-M10x125I	10	40	50	15	20	M10x1.25	10
F-M12x125I	12	48	62	24	20	M12x1.25	12
F-M16x150I	16	64	82	32	23	M16X1.5	16
F-M20x150I	20	80	102	40	30	M20x1.5	20
F-M27x200I	30	110	139	51	45	M27x2.0	30

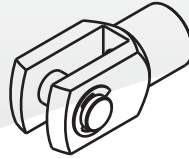

Horquilla Hembra Y

Cómo Ordenar

	F	M16	x	150	Y		
	①	②	③	④			
① Código Accesorio	M10	M12	M16	M20	M27	M36	M42
② Rosca de Tornillo	125: 1.25mm		150: 1.5mm		200: 2.0mm		
③ Paso de Rosca							Y: Horquilla Y Hembra
④ Código							

Dimensiones

Item	E	G	H	I
F-M10x125Y	M10x1.25	5 25	10	10

Item	NA	NC	ND	NP	NQ
F-M12x125Y	25.4	12	48	24	62
F-M16x150Y	32	16	64	32	80
F-M20x150Y	44.4	20	80	40	101
F-M27x200Y	54	30	110	55	139

Item	NM	NH	PA	PB
F-M12x125Y	12	M12x1.25	32.4	26.2
F-M16x150Y	16	M16x1.5	39	32.8
F-M20x150Y	20	M20x1.5	53.4	45.2
F-M27x200Y	30	M27x2.0	64.2	54.8

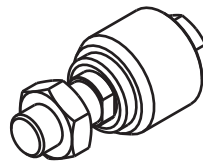
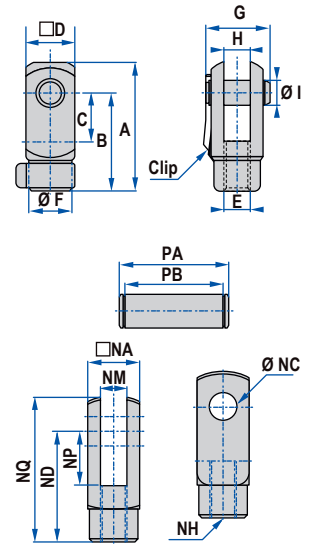

Junta Flotante F

Cómo Ordenar

	F	M22	x	150	F		
	①	②	③	④			
① Código Accesorio	M10	M12	M16	M20	M27	M36	
② Rosca de Tornillo	125: 1.25mm		150: 1.5mm		200: 2.0mm		
③ Paso de Rosca							F: Junta Flotante
④ Código							

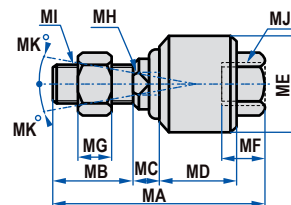

Dimensiones

Item	MA	MB	MC	MD	ME	MF	MG	MH	MIMJ	MK
F-M8x125F	51	20	6	17	24	10.5	6	8	M8x1.25	13
F-M10x125F	58	22	7	21	26	11	6	10	M10x1.25	12
F-M12x125F	58	22	8	21	28	11.5	7	12	M12x1.25	12
F-M16x150F	90	27	10	41	44.5	19	8	17	M16x1.5	7
F-M20x125F	102	29	13	46	53	22	10	22	M20x1.5	10
F-M27x200F	136.5	40	14.5	52.5	59.5	40	13.5	27	M27x2.0	5

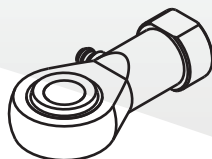

Rótula U

Cómo Ordenar

① Código Accesorio	② Rosca de Tornillo	③ Paso de Rosca	④ Código
F	M10	125	U
	M12	1.25mm	U: Rótula
	M16	1.5mm	
	M20	2.0mm	
	M27		
	M36		

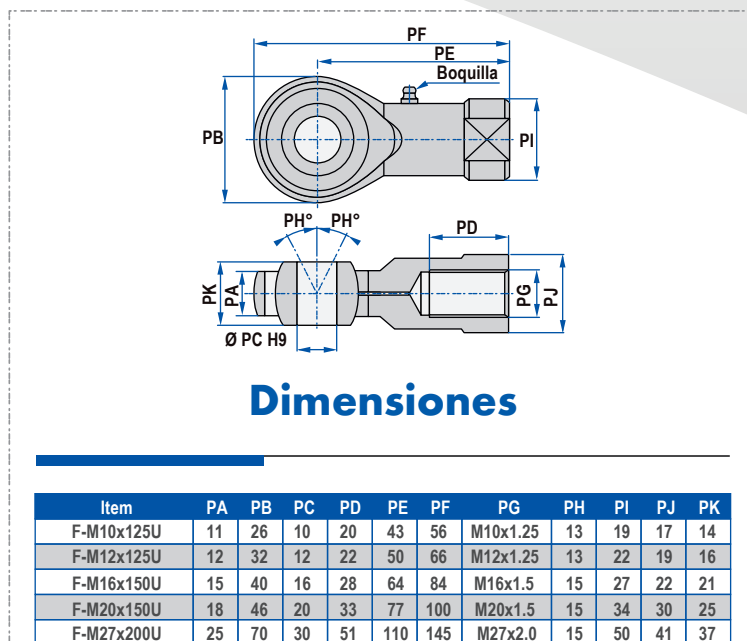

ROMIHN[®]
Automation Technology

Strokmatic[®]
Automation Technology

www.romihn.com.mx

222 940 0313

contactcenter@romihn.com.mx

Ubicaciones

 Puebla	222 531 2925
 CDMX	553 408 1489
 Guadalajara	332 870 3192
 Querétaro	442 668 1414
 Tijuana	664 275 4360
 Santa Catarina	812 254 5561
 Aguascalientes	449 205 4364