

Compendium of HFR Series

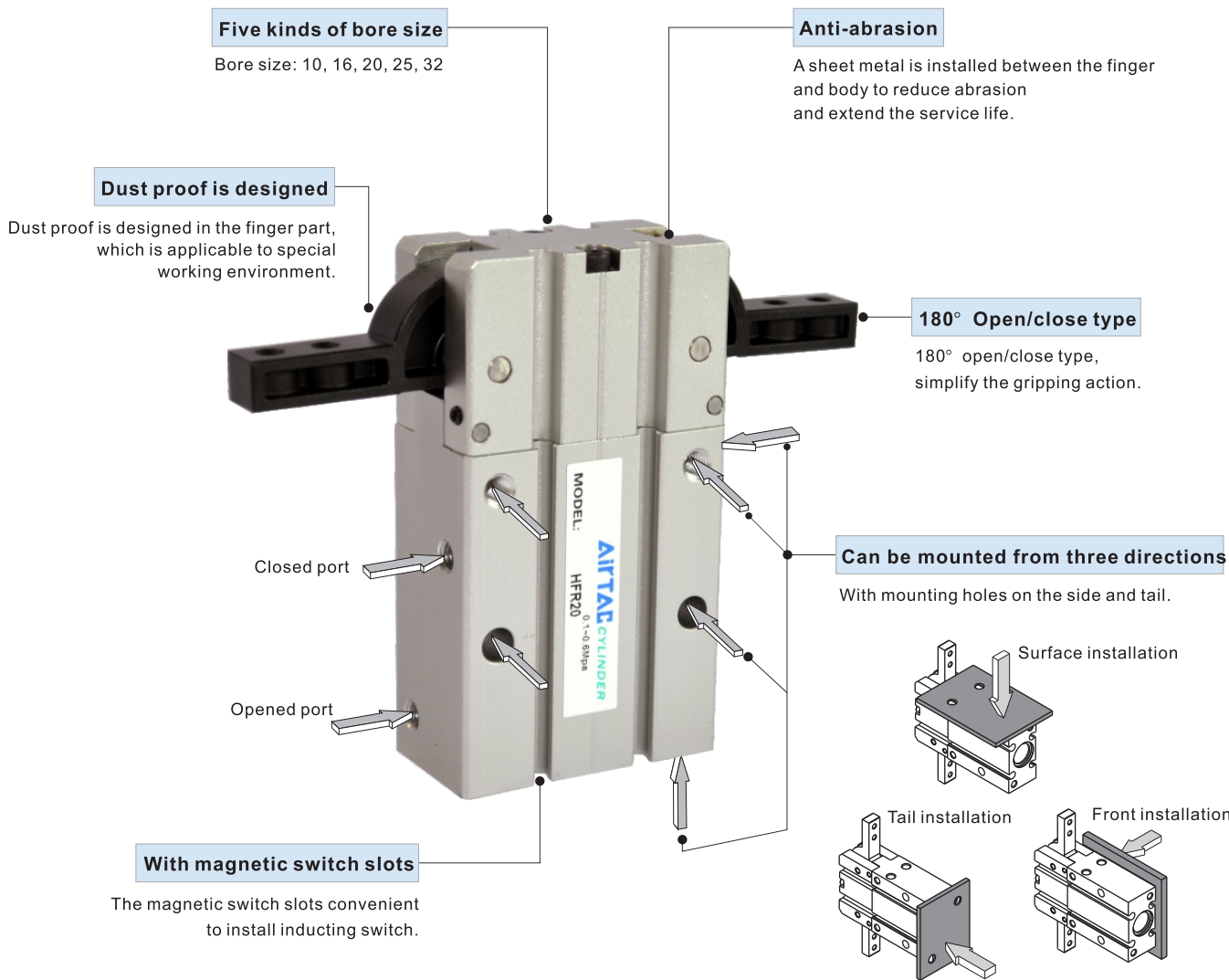

| Bore size (mm) | 10 | 16 | 20 | 25 | 32 |
|-------------------------|--|---------|---------|---------|---------|
| Acting type | Double acting | | | | |
| Fluid | Air(to be filtered by 40 μm filter element) | | | | |
| Operating pressure | 0.15~0.7MPa(21~100psi)(1.5~7.0bar) | | | | |
| Temperature °C | -20~70 | | | | |
| Lubrication | Cylinder: Not required; Gripper jaws: Lubricate grease | | | | |
| Cushion type | Bumper | | | | |
| Max. frequency | 60(c.p.m) | | | | |
| Repeatability | ±0.2mm | | | | |
| Gripping force [Note1] | 0.16N.m | 0.55N.m | 1.10N.m | 2.30N.m | 5.00N.m |
| Open or close angle | Open: -2° ~ -5° Close: 180° ± 2° | | | | |
| Port size | M5×0.8 | | | | |
| Sensor switches [Note2] | CMSHDMSH(S) | | | | |

[Note1] The gripping force is the value when the operating pressure is 0.5Mpa.

[Note2] Sensor switch should be ordered additionally, please refer to P353 for detail of sensor switch.

Example

Screw down

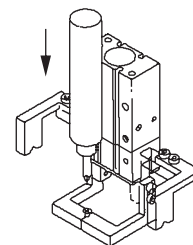

Clamping cable

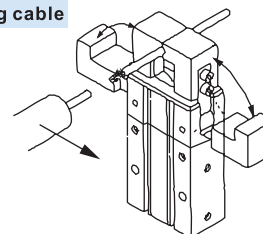



Symbol

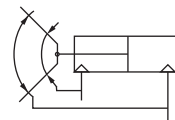

Ordering code

HFR 20

① ② ③

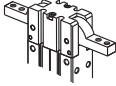
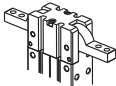
| ① Model | ② Bore size | ③ Mounting type |
|----------------------------------|----------------------------|--|
| HFR: 180° open/close air gripper | 10 16 20 25 32 | Blank: Mounting through tapped holes  N: Mounting through holes (tapped in open/close direction)  |

[Note] HFR series are all attached with magnet.

Inner structure and material of major parts

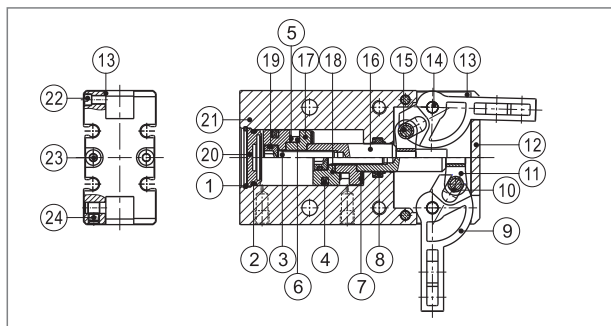

| NO. | Item | Material | NO. | Item | Material |
|-----|-------------------|--------------------------------------|-----|-------------------|-----------------|
| 1 | C clip | Spring steel | 12 | Front cover | Aluminum alloy |
| 2 | O-ring | NBR | 13 | Sheet metal | Stainless steel |
| 3 | Countersink screw | Carbon steel | 14 | Pin | Stainless steel |
| 4 | Piston seal | NBR | 15 | Pin | Stainless steel |
| 5 | Magnet washer | NBR | 16 | Piston rod | Stainless steel |
| 6 | Magnet | Sintered metal (Neodymium-iron-iron) | 17 | Magnet holder | Aluminum alloy |
| | | | 18 | Piston | Aluminum alloy |
| 7 | Bumper | TPU | 19 | O-ring | NBR |
| 8 | Rod packing | NBR | 20 | Back cover | Aluminum alloy |
| 9 | Gripping jaws | Stainless steel | 21 | Body | Aluminum alloy |
| 10 | Pin sheath | Stainless steel | 22 | Pin | Stainless steel |
| 11 | Push block | Stainless steel | 23 | Countersink screw | Carbon steel |
| | | | 24 | Countersink screw | Carbon steel |

Dimensions

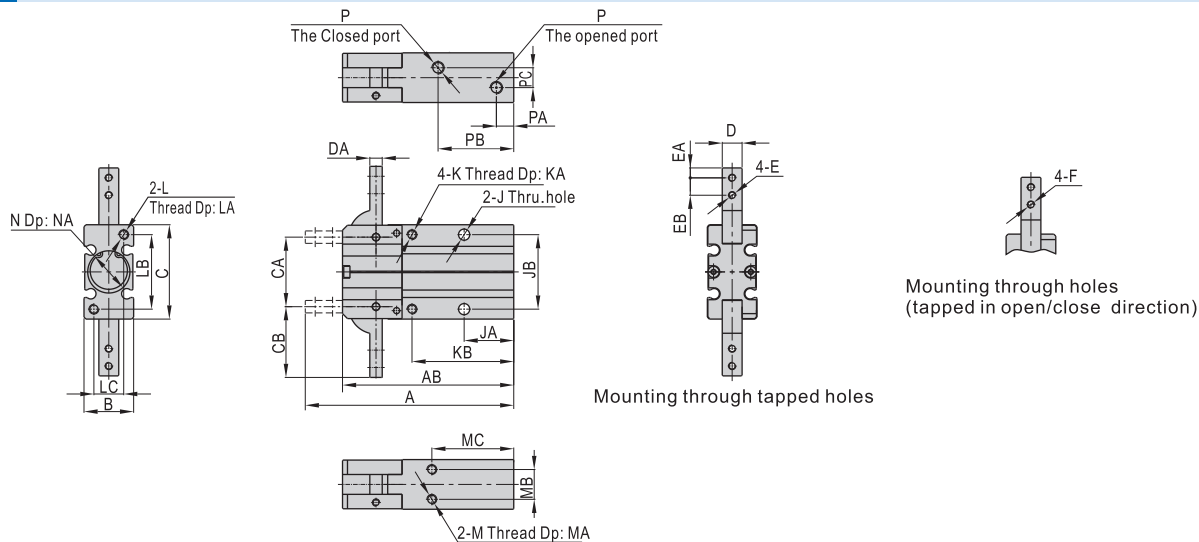

| Bore size\Item | A | AB | B | C | CA | CB | D | DA | E | F | EA | EB | J | JA | JB | K | KA |
|----------------|-------|-----|----|----|----|------|----|----|--------|------|----|----|------|----|----|--------|----|
| 10 | 71 | 58 | 15 | 30 | 22 | 23.5 | 6 | 4 | M3×0.5 | Φ3.3 | 3 | 6 | Φ3.3 | 18 | 24 | M3×0.5 | 6 |
| 16 | 84 | 69 | 20 | 38 | 28 | 28.5 | 8 | 5 | M3×0.5 | Φ3.3 | 4 | 7 | Φ4.5 | 20 | 30 | M4×0.7 | 8 |
| 20 | 106 | 86 | 26 | 48 | 36 | 37 | 10 | 8 | M4×0.7 | Φ4.5 | 5 | 9 | Φ5.5 | 25 | 36 | M5×0.8 | 10 |
| 25 | 131 | 107 | 30 | 58 | 45 | 45 | 12 | 10 | M5×0.8 | Φ5.5 | 6 | 12 | Φ6.5 | 30 | 42 | M6×1.0 | 12 |
| 32 | 158.5 | 122 | 40 | 72 | 55 | 62.5 | 14 | 12 | M6×1.0 | Φ6.5 | 9 | 16 | Φ6.5 | 35 | 46 | M6×1.0 | 12 |

| Bore size\Item | KB | L | LA | LB | LC | M | MA | MB | MC | N | NA | P | PA | PB | PC |
|----------------|----|--------|----|----|----|--------|----|----|----|-----------------------------------|-----|--------|----|------|----|
| 10 | 35 | M3×0.5 | 6 | 24 | 9 | M3×0.5 | 4 | 9 | 30 | Φ11 ^{+0.05} ₀ | 1.5 | M5×0.8 | 7 | 28.5 | 3 |
| 16 | 41 | M4×0.7 | 8 | 30 | 12 | M4×0.7 | 5 | 12 | 33 | Φ17 ^{+0.05} ₀ | 1.5 | M5×0.8 | 7 | 30.5 | 8 |
| 20 | 50 | M5×0.8 | 10 | 38 | 16 | M5×0.8 | 8 | 14 | 42 | Φ21 ^{+0.05} ₀ | 1.5 | M5×0.8 | 8 | 38.5 | 12 |
| 25 | 60 | M6×1.0 | 12 | 46 | 18 | M6×1.0 | 10 | 16 | 50 | Φ26 ^{+0.05} ₀ | 1.5 | M5×0.8 | 8 | 48 | 14 |
| 32 | 64 | M6×1.0 | 14 | 46 | 26 | M6×1.0 | 12 | 26 | 59 | Φ34 ^{+0.05} ₀ | 2 | M5×0.8 | 9 | 56 | 18 |

How to select product

1. Confirmation of effective gripping force

- 1.1) Though the coefficient of friction between the attachments and the workpiece is different, select a gripping force which is 10 to 20 times greater than the workpiece weight.
- 1.2) If high acceleration or impact forces are encountered during motion, a further margin of safety should be considered.

Example: When the workpiece weight is 0.05 and the gripping point distance L is 30mm, the operating pressure will be 5kgf/cm².

Effective gripping force = 0.05kg × 20 times × 9.8m/s² = more than 10N

Model selection: HFR16 is recommended. The effective gripping force is 17N, which is 20 times greater than the set value of gripping force.

- 1.3) The finger thrust is expressed as F, when both fingers and attachments are in full contact with the workpiece as shown in the figure below.

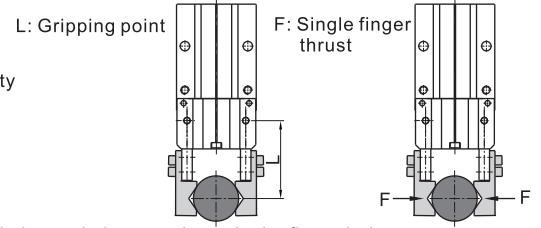

2. Connection between gripping force and gripping point distance

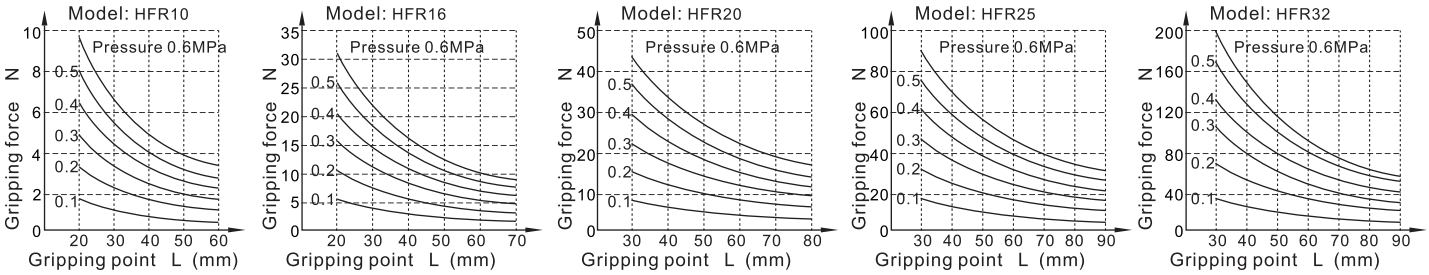

3. The selection of the gripping point

- 3.1) Please select the gripping point within the limited field shown left. Over the limits, gripping jaws would be subjected to excessive torque loads, and lead to short life of the air gripper.
- 3.2) In the allowable range of gripping point, it is better to design for short and light fittings. If the fittings are long and heavy, the inertia force when the finger is open and close will become larger, and the performance of gripping jaw will be degraded, at the same time it will affect the life.

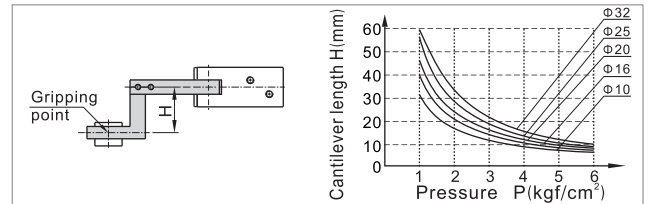

Installation and application

1. Due to the abrupt changes, the pressure is low, which will lead to the decrease of the gripping force and falling of the work-pieces. In order to avoid the harm to the human body and damage to the equipment, anti-dropping device must be equipped.
2. Don't use the air gripper under strong external force and impact force.
3. When install and fix the air gripper, avoid falling down, collision and damage.
4. When fixing the gripping jaw parts, don't twist the gripping jaw.
5. There are several kinds of installation method, and the torque of fastening screw must be within the prescribed moment range shown in the below chart. If the locking moment is too large, it will cause the dysfunctional. If the locking moment is too small, it will cause the position deviation and fall.

Tail installation type

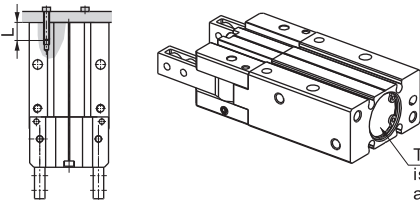

| Bore size | The bolts type | Max. locking moment | Max. screwed depth | The aperture of the positioning bore | The depth of the positioning bore |
|-----------|----------------|---------------------|--------------------|--------------------------------------|-----------------------------------|
| 10 | M3×0.5 | 1.0N.m | 6mm | Φ11mmH9 | 1.5mm |
| 16 | M4×0.7 | 2.0N.m | 8mm | Φ17mmH9 | 1.5mm |
| 20 | M5×0.8 | 4.5N.m | 10mm | Φ21mmH9 | 1.5mm |
| 25 | M6×1.0 | 7.0N.m | 12mm | Φ26mmH9 | 1.5mm |
| 32 | M6×1.0 | 7.0N.m | 14mm | Φ34mmH9 | 2.0mm |

The installation of the front threaded hole

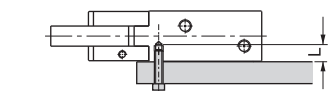

| Bore size | The bolts type | Max. locking moment(Nm) | Max. screwed depth(mm) |
|-----------|----------------|-------------------------|------------------------|
| 10 | M3×0.5 | 1.0 | 6 |
| 16 | M4×0.7 | 2.0 | 8 |
| 20 | M5×0.8 | 4.5 | 10 |
| 25 | M6×1.0 | 7.0 | 12 |
| 32 | M6×1.0 | 7.0 | 14 |

The installation of the front through hole

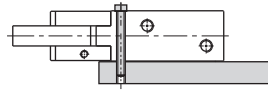

| Bore size | The bolts type | Max. locking moment (Nm) |
|-----------|----------------|--------------------------|
| 10 | M3×0.5 | 1.0 |
| 16 | M4×0.7 | 2.0 |
| 20 | M5×0.8 | 4.5 |
| 25 | M6×1.0 | 7.0 |
| 32 | M6×1.0 | 7.0 |

Surface installation type

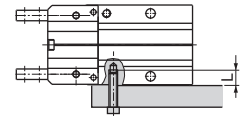

| Bore size | The bolts type | Max. locking moment(Nm) | Max. screwed depth(mm) |
|-----------|----------------|-------------------------|------------------------|
| 10 | M3×0.5 | 0.6 | 4 |
| 16 | M4×0.7 | 1.5 | 5 |
| 20 | M5×0.8 | 3.5 | 8 |
| 25 | M6×1.0 | 6.0 | 10 |
| 32 | M6×1.0 | 6.0 | 12 |

6. The installation method of the gripping jaw fittings. When install the gripping jaw fittings, you have to pay particular attention that you can only hold the gripping jaw by using spanner, and then lock the screws with allen wrench. Never clamp the body directly and then lock the screws, otherwise the parts will be easily damaged.

| Bore size | The bolts type | Max. locking moment (Nm) |
|-----------|----------------|--------------------------|
| 10 | M3×0.5 | 0.6 |
| 16 | M3×0.5 | 0.6 |
| 20 | M4×0.7 | 0.8 |
| 25 | M5×0.8 | 1.5 |
| 32 | M6×1.0 | 3.0 |

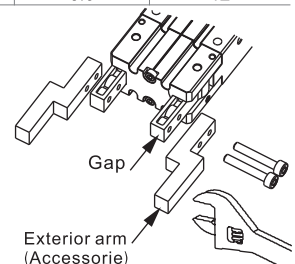

7. Other contents of installation and operation are the same with those of HFY. Refer to the "Installation and Operation" instruction of HFY.