

Compendium of JSI Series

JSI Standard cylinder
Bore size: 32, 40, 50, 63, 80, 100, 125

Convenient and fast fix sensor switch
Sensor switch can be directly fixed on the cylinder, which is convenient and fast.

No tie rod cylinder
The cylinder barrel is aluminum profile with hard anodizing treatment.

Adjustable air buffer
With adjustable air buffer on the front and back cover

Four kinds of cylinder joints
I Knuckle Y Knuckle Floating Joint Universal Joint

Multi-mounting accessories
LB FA FB CA CB CR TC TCM1 TCM2

Multi-type cylinder
JSI: Double acting type JSID: Double rod type JSIJ: Adjustable stroke type

Criteria for selection: Cylinder thrust

Unit: Newton(N)

Bore size	Rod size	Acting type	Pressure area(mm ²)	Operating pressure(MPa)									
				0.1	0.2	0.3	0.4	0.5	0.6	0.7	0.8	0.9	
32	12	Double acting	Push side	804	80.4	160.8	241.2	321.6	402.0	482.4	562.8	643.2	723.6
			Pull side	690	69.0	138.0	207.0	276.0	345.0	414.0	483.0	552.0	621.0
40	16	Double acting	Push side	1256	125.6	251.2	376.8	502.4	628.0	753.6	879.2	1002.4	1130.4
			Pull side	1055	105.5	211.0	316.5	422.0	527.5	633.0	738.5	844.0	949.5
50	20	Double acting	Push side	1963	196.3	392.6	588.9	785.2	981.5	1177.8	1374.1	1570.4	1766.7
			Pull side	1649	164.9	329.8	494.7	659.6	824.5	989.4	1154.3	1399.2	1484.1
63	20	Double acting	Push side	3117	311.7	623.4	935.1	1246.8	1558.5	1870.2	2181.9	2493.6	2805.3
			Pull side	2803	280.3	560.6	840.9	1121.2	1401.5	1681.8	1962.1	2242.4	2522.7
80	25	Double acting	Push side	5026	502.6	1005.2	1507.8	2010.4	2513.0	3015.6	3518.2	4020.8	4523.4
			Pull side	4536	453.6	907.2	1360.8	1814.4	2268.0	2721.6	3175.2	3628.8	4082.4
100	30	Double acting	Push side	7853	785.3	1570.6	2355.9	3141.2	3926.5	4711.8	5497.4	6282.9	7068.5
			Pull side	7147	714.7	1429.4	2144.1	2858.9	3573.6	4288.3	5003.0	5717.7	6432.4
125	32	Double acting	Push side	12272	1227.2	2454.4	3681.6	4908.8	6136.0	7363.2	8590.4	9817.6	11044.8
			Pull side	11468	1146.8	2293.6	3440.4	4587.2	5734.0	6880.8	8027.6	9174.4	10321.2

Installation and application



- When load changes in the work, the cylinder with abundant output capacity shall be selected.
- Relative cylinder with high temperature resistance or corrosion resistance shall be chosen under the condition of high temperature or corrosion.
- Necessary protection measure shall be taken in the environment with higher humidity, much dust or water drops, oil dust and welding dregs.
- Dirty substances in the pipe must be eliminated before cylinder is connected with pipeline to prevent the entrance of particles into the cylinder.
- The medium used by cylinder shall be filtered to 40 μm or below.
- Anti-freezing measure shall be adopted under low temperature environment to prevent moisture freezing.
- The cylinder shall be carried out test run without load before application. Prior to run, buffer shall be turned to the minimum and gradually released to avoid the damage on cylinder caused by excessive impact.
- The cylinder shall avoid the influence of side load in operation to maintain the normal work of cylinder and extend the service life.
- If the cylinder is dismantled and stored for a long time, please conduct anti-rust treatment to the surface. Anti-dust caps shall be added in air inlet and outlet ports.



Specification

Bore size(mm)	32	40	50	63	80	100	125
Acting type	Double acting						
Fluid	Air(to be filtered by 40 μm filter element)						
Mounting type	JSI	Basic FA FB CA CB CR LB TC TCM1 TCM2					
	JSID、JSIJ	Basic FA LB TC TCM1 TCM2					
Operating pressure	0.15~1.0MPa(22~145psi)(1.5~10.0bar)						
Proof pressure	1.5MPa(215psi)(15bar)						
Temperature °C	-20~70						
Speed range mm/s	30~800						30~500
Stroke tolerance	0~250 ^{+1.0} ₀		251~1000 ^{+1.5} ₀		1001~1500 ^{+2.0} ₀		
Cushion type	Variable cushion						
Adjustable cushion stroke	24					32	40
Port size [Note1]	1/8"	1/4"	3/8"		1/2"		

[Note1] PT thread, G thread are available.

Symbol

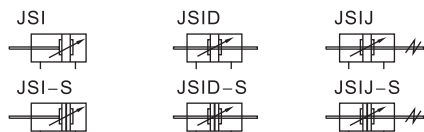

Product feature

1. JIS standard cylinder.
2. The seal of piston adopts heterogeneous two way seal structure. It's dimension is tight and it has the function of greasel reservation.
3. The cylinder barrel is aluminum profile with hard anodizing treatment.
4. Compared with ISO15552 standard cylinder, the cylinder of JSI series with the same cylinder diameter is shorter.
5. The buffer adjustment of cylinder is smooth and steady.
6. Cylinders and mounting accessories for installation with several specifications are optional.

Stroke

Bore size (mm)	Standard stroke (mm)	Max.std stroke	Max. stroke
32	25 50 75 80 100 125 150 160 175 200 250 300 350 400 450 500	1000	1800
40	25 50 75 80 100 125 150 160 175 200 250 300 350 400 450 500 600 700 800 900 1000	1200	1800
50	25 50 75 80 100 125 150 160 175 200 250 300 350 400 450 500 600 700 800 900 1000	1200	1800
63	25 50 75 80 100 125 150 160 175 200 250 300 350 400 450 500 600 700 800 900 1000	1500	1800
80	25 50 75 80 100 125 150 160 175 200 250 300 350 400 450 500 600 700 800 900 1000	1500	1800
100	25 50 75 80 100 125 150 160 175 200 250 300 350 400 450 500 600 700 800 900 1000	1500	1800
125	25 50 75 80 100 125 150 160 175 200 250 300 350 400 450 500 600 700 800 900 1000	1500	1800

[Note] Consult us for non-standard stroke.

Ordering code

JSI 80 x 50 S

JSID 80 x 50 S

JSIJ 80 x 50-20 S



① Model	② Bore size	③ Stroke	④ Adjustable stroke	⑤ Magnet	⑥ Mounting type[Note1]	⑦ Thread type
SI: Double acting type	32 40 50 63 80 100 125	Refer to stroke table for details	No this code	Blank: Without magnet S: With magnet	Blank	Blank: PT G: G
JSID: Double rod type					LB	
					FA	
JSIJ: Adjustable stroke type		FB				
		CA				
		CB				
		CR				
		TC				
		Blank				
LB						
		FA				
		TC				

[Note1] Please refer to page 62~64 for details of accessories; TC is used with TCM1, TCM2.

Inner structure and material of major parts

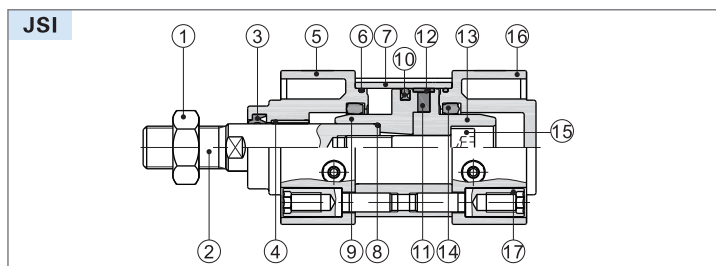

NO.	Item	Material
1	Rod nut	Carbon steel\Stainless steel
2	Piston rod	Carbon steel with 20 μm chrome plated or Stainless steel
3	Front cover packing	NBR
4	Bushing	Wear resistant material
5	Front cover	Aluminum alloy
6	O-ring	NBR
7	Barrel	Aluminum alloy
8	O-ring	NBR
9	Piston	Aluminum alloy
10	Piston seal	NBR
11	Magnet	Plastic
12	Wear ring	Wear resistant material
13	Magnet holder	Aluminum alloy
14	Buffer gasket	NBR
15	Screw	Carbon steel
16	Back cover	Aluminum alloy
17	Tie-rod nut	Carbon steel

Dimensions

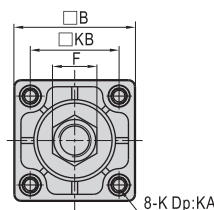
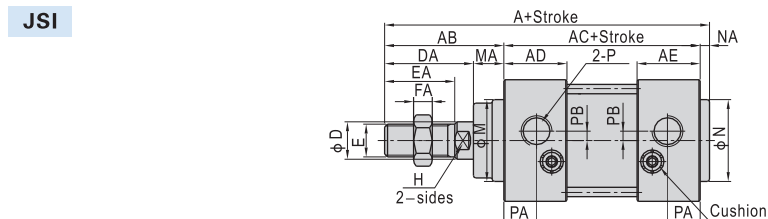

Bore size\Item	A	AB	AC	AD	AE	B	D	DA	E	EA	F	FA	H	M	MA	K(Without TC)	K(With TC)	KA(Without TC)	KA(With TC)	KB	N	NA	P	PA	PB
32	135	47	84	27	27	46	12	34	M10×1.25	22	17	6	10	30	13	M6	M5	16	14	32.5	30	4	1/8"	13	4
40	139	51	84	27	27	52	16	38	M14×1.5	30	19	8	14	35	13	M6	M5	16	14	38	35	4	1/4"	14	4
50	156	58	94	31.5	31.5	65	20	44	M18×1.5	35	27	11	18	40	14	M8	M6	17	16	46.5	40	4	1/4"	15.5	5
63	156	58	94	30.5	30.5	75	20	44	M18×1.5	35	27	11	18	45	14	M8	M6	17	16	56.5	45	4	3/8"	16.5	9
80	190	72	114	38	38	95	25	52	M22×1.5	40	32	13	22	45	20	M10	M8	21	16	72	45	4	3/8"	19	11.5
100	190	72	114	38	38	114	30	52	M26×1.5	40	36	13	26	55	20	M10	M8	21	16	89	55	4	1/2"	19	17
125	223	97	120	38	38	137	32	70	M27×2.0	54	41	13.5	27	60	27	M12	M12	21	18	110	60	6	1/2"	19	17

Remark: The dimensions of magnet type cylinder are the same as non-magnet type cylinder.

JSID

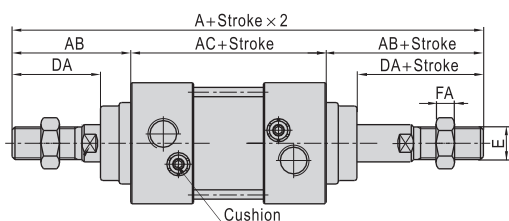

JSIJ

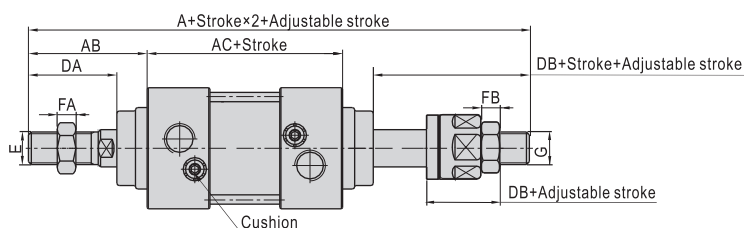

Bore size\Item	A(JSID)	A(JSIJ)	AB	AC	DA	DB	E	FA	FB	G
32	178	171	47	84	34	27	M10X1.25	6	6	M10X1.25
40	186	176	51	84	38	28	M14X1.5	8	7	M12X1.25
50	210	195	58	94	44	29	M18X1.5	11	8	M16X1.5
63	210	195	58	94	44	29	M18X1.5	11	8	M16X1.5
80	258	241.5	72	114	52	35.5	M22X1.5	13	10	M20X1.5
100	258	248.5	72	114	52	42.5	M26X1.5	13	13.5	M27X2.0
125	314	286.5	97	120	70	42.5	M27X2.0	13.5	13.5	M27X2.0

Remark:

- The dimensions of magnet type cylinder are the same as non-magnet type cylinder.
- The unmarked dimension is the same as JSI standard type.

List for ordering code of accessories

Accessories Bore size	Mounting accessories							
	LB	FA/FA	CA	CB	CR	TC	TCM1	TCM2
32	F-JSI32LB	F-SI32FA	F-JSI32CA	F-JSI32CB	F-JSI32CR	F-SI32TC	F-SI32TCM1	F-SI32TCM2
40	F-JSI40LB	F-SI40FA	F-JSI40CA	F-JSI40CB	F-JSI40CR	F-SI40TC	F-SI40TCM1	F-SI40TCM2
50	F-JSI50LB	F-SI50FA	F-JSI50CA	F-JSI50CB	F-JSI50CR	F-SI50TC	F-SI40TCM1	F-SI40TCM2
63	F-JSI63LB	F-SI63FA	F-JSI63CA	F-JSI63CB	F-JSI50CR	F-SI63TC	F-SI63TCM1	F-SI63TCM2
80	F-JSI80LB	F-SI80FA	F-JSI80CA	F-JSI80CB	F-JSI80CR	F-SI80TC	F-SI63TCM1	F-SI63TCM2
100	F-JSI100LB	F-SI100FA	F-JSI100CA	F-JSI100CB	F-JSI80CR	F-SI100TC	F-SI125TCM1	F-SI125TCM2
125	F-JSI125LB	F-JSI125FA	F-JSI125CA	F-JSI125CB	F-JSI125CR	F-SI125TC	F-SI125TCM1	F-SI125TCM2

Accessories Bore size	Knuckle			
	I: I Knuckle	Y: Y Knuckle	F: F Knuckle	U: U Knuckle
32	F-M10X125I	F-M10X125Y	F-M10X125F	F-M10X125U
40	F-M14X150I	F-M14X150Y	F-M14X150F	F-M14X150U
50	F-M18X150I	F-M18X150Y	F-M18X150F	F-M18X150U
63	F-M18X150I	F-M18X150Y	F-M18X150F	F-M18X150U
80	F-M22X150I	F-M22X150Y	F-M22X150F	-
100	F-M26X150I	F-M26X150Y	F-M26X150F	F-M26X150U
125	F-M27X200I	F-M27X200Y	F-M27X200F	F-M27X200U

Accessory selection

Accessories Cylinder model	Mounting accessories									Knuckle [Note1]			
	LB	FA	FB	CA	CB	CR	TC	TCM1	TCM2	I	Y	U	F
JSI	Standard	●	●	●	●	●	●	●	●	●	●	●	●
	With magnet	●	●	●	●	●	●	●	●	●	●	●	●
JSID	Standard	●	●	×	×	×	×	●	●	●	●	●	●
	With magnet	●	●	×	×	×	×	●	●	●	●	●	●
JSIJ	Standard	●	●	×	×	×	×	●	●	●	●	●	●
	With magnet	●	●	×	×	×	×	●	●	●	●	●	●

[Note1] Please refer to P349~352 for knuckle detail.

Material of accessories

Accessories Bore size	Mounting accessories									Knuckle			
	LB	FA	FB	CA	CB	CR	TC	TCM1	TCM2	I	Y	F	U
32~63	□	●	●	△	△	◇	◇	□	●	□	□	□	□
80、100	□	●	●	△	△	◇	◇	□	●	□	□	□	□
125	□	■	■	□	□	◇	◇	□	●	□	□	□	□

●— Aluminum alloy, ■— Cast steel, ◇— Nodular cast iron, △— FC25; □— Carbon steel.

Dimensions

LB

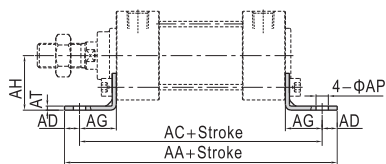

CA

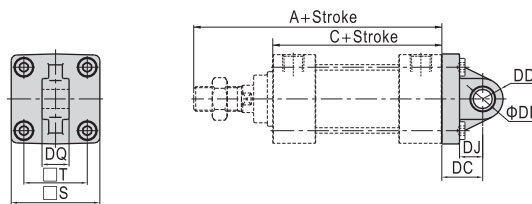

Bore size\Item	AA	AC	AD	AE	AF	AG	AH	AP	AT
32	146	128	9	50	32	22	30	7	3
40	154	132	11	55	38	24	33	9	3
50	170	148	11	70	46	27	40	9	3
63	176	148	14	80	56	27	45	12	4
80	202	174	14	100	72	30	55	12	5
100	210	178	16	120	89	32	65	14	5
125	250	210	20	136	90	45	81	14	8

Bore size\Item	A	C	S	T	DC	DD	DE	DJ	DQ
32	131	84	46	32.5	23	10.5	10	13	13.8
40	135	84	52	38	23	11	10	13	13.8
50	152	94	65	46.5	30	15	14	17	19.8
63	152	94	75	56.5	30	15	14	17	19.8
80	186	114	95	72	42	17.5	22	27	29.8
100	186	114	114	89	42	17.5	22	27	29.8
125	217	120	136	110	50	28	25	28	31.8

FA/FB

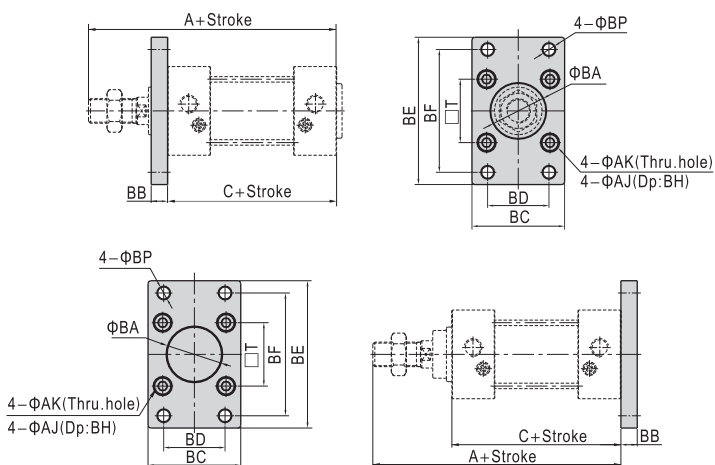

Bore size\Item	A	C	AJ	AK	BA	BB	BC	BD	BE	BF	BH	BP	T
32	131	84	11	6.5	30.5	10	47	32	80	64	6.5	7	32.5
40	135	84	11	6.5	35.5	10	53	36	90	72	6.5	9	38
50	152	94	14	9	40.5	12	65	45	108	90	8.5	9	46.5
63	152	94	14	9	45.5	12	75	50	118	100	8.5	9	56.5
80	186	114	17	11	45.5	16	95	63	150	126	10.5	12.5	72
100	186	114	17	11	55.5	16	115	75	176	150	10.5	14.5	89
125	217	120	19	13	60.5	20	138	102	216	180	12.5	14	110

CB

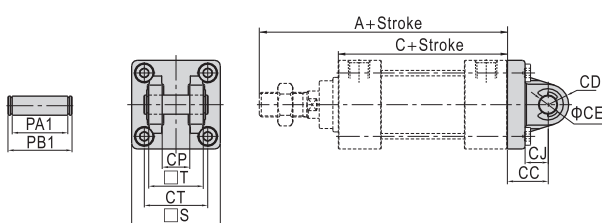

Bore size\Item	A	C	CC	CD	CE	CJ	CP	CT	PA1	PB1	S	T
32	131	84	23	10.5	10	14	14.2	32.5	28.8	34.6	46	28
40	135	84	23	11	10	14	14.2	38	28.8	34.6	52	28
50	152	94	30	15	14	18	20.2	46.5	40.8	47	65	40
63	152	94	30	15	14	18	20.2	56.5	40.8	47	75	40
80	186	114	42	20	22	27	30.2	72	60.8	69.2	95	60
100	186	114	42	20	22	27	30.2	89	60.8	69.2	114	60
125	217	120	50	25	25	32	32.2	110	64.8	73.2	136	64

CR

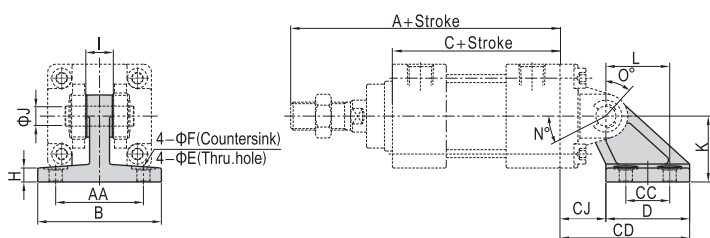

Bore size\Item	A	AA	B	C	CC	CD	CJ	D	E	F	H	I	J	K	L	N	O	N+O+90°
32	131	44	62	84	22	65	23	42	6.6	12	7	13.8	10	33	32	25	45	160
40	135	44	62	84	22	65	23	42	6.6	12	7	13.8	10	33	32	25	45	160
50	152	60	81	94	30	84.5	31.5	53	9	15	8	19.8	14	45	43	40	60	190
63	152	60	81	94	30	84.5	31.5	53	9	15	8	19.8	14	45	43	40	60	190
80	186	86	111	114	45	120	47	73	11	18	10	29.8	22	65	64	30	55	175
100	186	86	111	114	45	120	47	73	11	18	10	29.8	22	65	64	30	55	175
125	217	110	136	120	60	143	53	90	13.5	20	14	31.8	25	75	78	30	50	170

[Note] CR can't be used alone, it must be used with CB.

TC

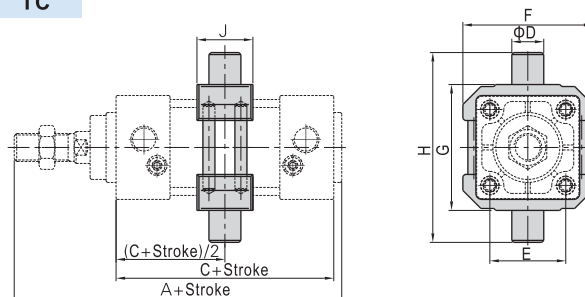

Bore size\Item	A	C	D	E	F	G	H	J
32	135	84	12	32.5	52	50	74	22
40	139	84	16	38	65	63	95	28
50	156	94	16	46.5	75	75	107	28
63	156	94	20	56.5	90	90	130	30
80	190	114	20	72	112	110	150	32
100	190	114	25	89	135	132	182	38
125	223	120	25	110	170	160	210	40

[Note] The TC accessory has been installed on the barrel of cylinder before it worked off, and the position of the accessories can not be adjusted arbitrarily.

If consumer orders the TC solely, he will not install it on the barrel of standard cylinder directly.

TCM1

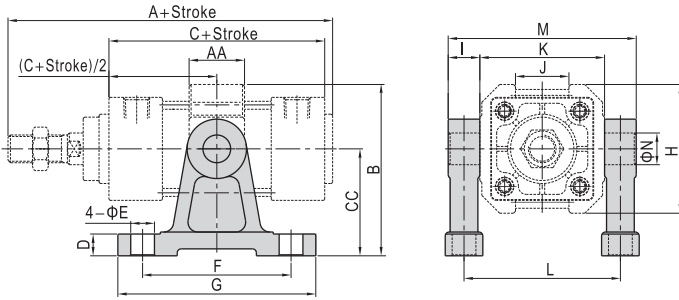

Bore size\Item	B	A	AA	C	CC	D	E	F	G	H	I	J	K	L	M	N
32	66	135	22	84	40	11	9	60	80	52	12	20	50	62	77	12
40	86.5	139	28	84	54	11	12	75	100	65	16	27	63	79	98	16
50	91.5	156	28	94	54	11	12	75	100	75	16	31	75	91	110	16
63	115	156	30	94	70	11	12	85	110	90	20	42	90	110	133	20
80	126	190	32	114	70	11	12	85	110	112	20	54	110	130	153	20
100	157.5	190	38	114	90	19	18	115	155	135	25	68	132	157	185	25
125	175	223	40	120	90	19	18	115	155	170	25	80	160	185	213	25

[Note] The installation position of the accessories can not be adjusted arbitrarily.

TCM2

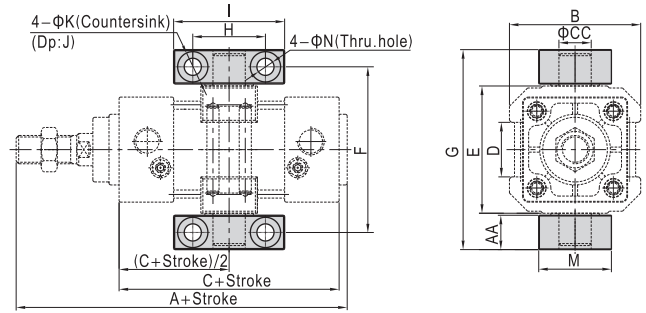

Bore size\Item	A	AA	B	C	CC	D	E	F	G	H	I	J	K	M	N
32	135	14	52	84	12	20	50	66	80	32	46	6.8	11	30	7
40	139	17	65	84	16	27	63	82	99	36	55	9	15	36	9
50	156	17	75	94	16	31	75	94	111	36	55	9	15	36	9
63	156	20.5	90	94	20	42	90	113.5	134	42	65	11	18	40	11
80	190	20.5	112	114	20	54	110	133.5	154	42	65	11	18	40	11
100	190	24.5	135	114	25	68	132	159.5	184	50	75	14	20	50	14
125	223	24.5	170	120	25	80	160	187.5	212	50	75	14	20	50	14

[Note] The installation position of the accessories can not be adjusted arbitrarily.