

### Compendium of HRQ Series

#### Higher manufacturing precision of working platform

The manufacturing precision of working platform is high, and is easy for installation, and is of precise orientation.

The center of working platform has a through hole, and pipe can be located and passed through this hole;

#### Double cylinder structure

Double cylinder structure, double output could be achieved.

#### Rack and pinion design

Rack and pinion design, stable functioning.

#### With magnetic switch slots

#### Three kinds of type could be chosen

Mini-sized Rotary Cylinder: 2, 3, 7  
Middle-sized Rotary Cylinder: 10, 20, 30, 50  
Large-sized Rotary Cylinder: 70, 100, 200

#### Simply to install

Guide hole is designed on the both side of the cylinder body (10~200) or undersurface (2~7), which is simply to install.

#### Two modes of buffer could be chosen

Adjustment bolt buffer and internal shock absorber could be chosen



### Installation and application

1. Dirty substances in the pipe must be eliminated before cylinder is connected with pipeline to prevent the entrance of impurities into the cylinder.
2. The medium used by cylinder shall be filtered to 40 μm or below.
3. Anti-freezing measure shall be adopted under low temperature environment to prevent moisture freezing.
4. If the cylinder is dismantled and stored for a long time, pay attention to conduct anti-rust treatment to the surface. Anti-dust caps shall be added in air inlet and outlet ports.

### Maximum allowed loading

| Loading type                            | Model |      |      |       |       |       |       |       |        |        |
|---|-------|------|------|-------|-------|-------|-------|-------|--------|--------|
|   | HRQ2  | HRQ3 | HRQ7 | HRQ10 | HRQ20 | HRQ30 | HRQ50 | HRQ70 | HRQ100 | HRQ200 |
| Maximum allowed radial loading (N)<br>  | 18    | 30   | 50   | 80    | 150   | 200   | 300   | 330   | 390    | 540    |
| Maximum allowed axial loading (N)<br>   | 35    | 50   | 70   | 80    | 150   | 200   | 300   | 300   | 500    | 740    |
| Maximum allowed bending moment (Nm)<br> | 0.8   | 1.1  | 1.5  | 2.5   | 4.0   | 5.5   | 10.0  | 12.0  | 18.0   | 25.0   |

### Actual torque output

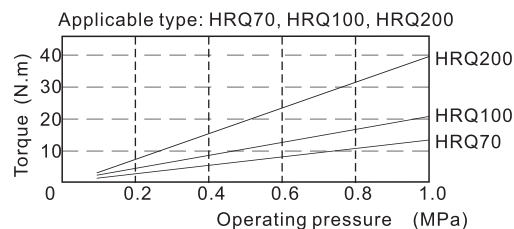
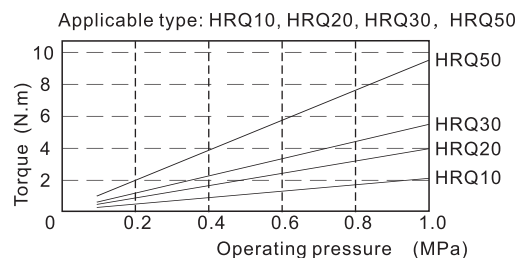
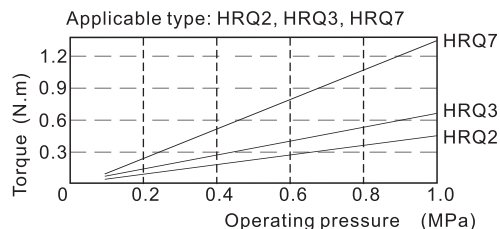



**Symbol**

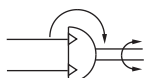

**Product feature**

1. Rack and pinion design, stable functioning.
2. Double cylinder structure, double output could be achieved.
3. The manufacturing precision of working platform is high, and is easy for installation, and is of precise orientation.
4. The center of working platform has a through hole, and pipe can be located and passed through this hole;
5. Guide hole is designed on the both side of the cylinder body (10~200) or undersurface (2~7), which is simply to install.
6. Two modes of buffer could be chosen, adjustment bolt buffer and internal shock absorber, the maximum buffer energy of internal shock absorber is 3-5 times that of adjustment bolt buffer.

**Specification**

| Specification                 | 2  | 3                                  | 7                                  | 10  | 20  | 30   | 50           | 70     | 100  | 200  |  |
|-------------------------------|--|------------------------------------|------------------------------------|-----|-----|------|--------------|--------|------|------|--|
| Acting type                   | Double rack and pinion(Double acting)        |                                    |                                    |     |     |      |              |        |      |      |  |
| Fluid                         | Air(to be filtered by 40 μ m filter element) |                                    |                                    |     |     |      |              |        |      |      |  |
| Operating pressure            | With adjustment bolt                         | 0.15~0.7MPa(22~100psi)(1.5~7.0bar) |                                    |     |     |      |              |        |      |      |  |
|                               | With internal shock absorber                 | -                                  | 0.15~0.7MPa(22~100psi)(1.5~7.0bar) |     |     |      |              |        |      |      |  |
| Proof pressure                | 1.2MPa(175psi)(12.0bar)                      |                                    |                                    |     |     |      |              |        |      |      |  |
| Temperature °C                | -20~70                                       |                                    |                                    |     |     |      |              |        |      |      |  |
| Angle adjustment range        | 0~190°                                       |                                    |                                    |     |     |      |              | 0~190° |      |      |  |
| Repeatable precision          | With adjustment bolt                         | 0.2°                               |                                    |     |     |      |              |        |      |      |  |
|                               | With internal shock absorber                 | -                                  | 0.05°                              |     |     |      |              |        |      |      |  |
| Theoretic moment (Nm)(0.5MPa) | 0.2  | 0.33                               | 0.63                               | 1.1 | 2.2 | 2.8  | 5.0          | 7.5    | 11.0 | 22.0 |  |
| Cushion type                  | With adjustment bolt                         | Rubber bumper                      |                                    |     |     |      |              |        |      |      |  |
|                               | With internal shock absorber                 | -                                  | Shock absorber                     |     |     |      |              |        |      |      |  |
| Port size                     | End ports                                    | M5×0.8                             |                                    |     |     |      | 1/8" [Note1] |        |      |      |  |
|                               | Side ports                                   | M5×0.8                             |                                    |     |     |      |              |        |      |      |  |
| Weight g                      | 120  | 175                                | 270                                | 535 | 940 | 1260 | 2060         | 2890   | 4100 | 7650 |  |

[Note1] PT thread, G thread and NPT thread are available.

Add) Refer to P353 for detail of sensor switch.

**Maximum allowed movement energy and rotation times**

| Model  | Maximal allowed energy (J) |                              | Rotation times (s/90°) |                              |
|--------|----------------------------|------------------------------|------------------------|------------------------------|
|        | With adjustment bolt       | With internal shock absorber | With adjustment bolt   | With internal shock absorber |
| HRQ2   | 0.0015                     | -                            | 0.2~0.7                | -                            |
| HRQ3   | 0.002                      | -                            | 0.2~0.7                | -                            |
| HRQ7   | 0.006                      | -                            | 0.2~1.0                | -                            |
| HRQ10  | 0.01                       | 0.04                         | 0.2~1.0                | 0.2~0.7                      |
| HRQ20  | 0.025                      | 0.12                         | 0.2~1.0                | 0.2~0.7                      |
| HRQ30  | 0.05                       | 0.12                         | 0.2~1.0                | 0.2~0.7                      |
| HRQ50  | 0.08                       | 0.30                         | 0.2~1.0                | 0.2~0.7                      |
| HRQ70  | 0.24                       | 1.1                          | 0.2~1.5                | 0.2~1.0                      |
| HRQ100 | 0.32                       | 1.6                          | 0.2~2.0                | 0.2~1.0                      |
| HRQ200 | 0.56                       | 2.9                          | 0.2~2.5                | 0.2~1.0                      |

[Note]

1: The movement energy should not exceed the allowed maximum energy, or the inner accessories of product would be damaged;

2: When the rotation times of with shock absorber is larger than the allowed tolerance, the bigger effect will be lost.

**Ordering code**

HRQ 20 A □

① ② ③ ④

| ① Model                               | ② Specification | ③ Cushion type   | ④ Thread type               |
|---------------------------------------|-----------------|--|-----------------------------|
| HRQ: Rotary Table/Rack & Pinion Style | 2               | Blank: With adjustment bolt                                    | No this code                |
|                                       | 3               |  |                             |
|                                       | 7               |  |                             |
|                                       | 10              |  |                             |
|                                       | 20              | Blank: With adjustment bolt<br>A: With internal shock absorber | Blank: PT<br>G: G<br>T: NPT |
|                                       | 30              |  |                             |
|                                       | 50              |  |                             |
|                                       | 70              |  |                             |
|                                       | 100             |  |                             |
|                                       | 200             |  |                             |

[Note] HRQ series are all attached with magnet.

### Inner structure and material of major parts

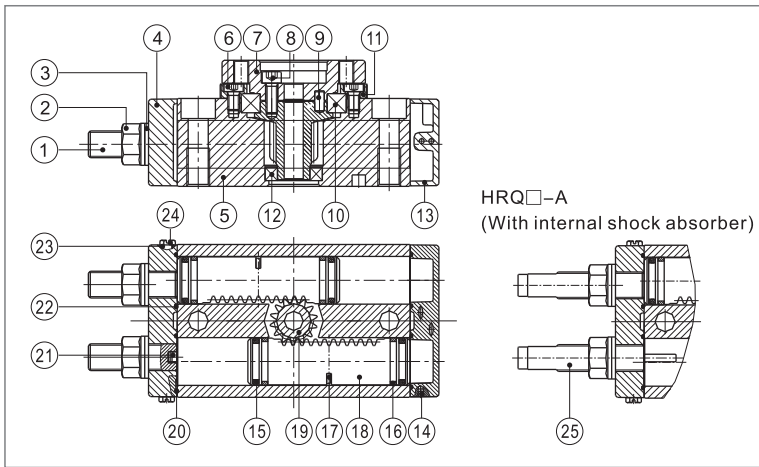

| NO. | Item                               | Material                     |
|-----|------------------------------------|------------------------------|
| 1   | Adjustment bore                    | Carbon steel                 |
| 2   | Hexagon nut                        | Carbon steel                 |
| 3   | Seal washer                        | Carbon steel & Rubber        |
| 4   | Front cover                        | Aluminum alloy               |
| 5   | Body                               | Aluminum alloy               |
| 6   | Hexagon socket head set bore       | Carbon steel                 |
| 7   | Table                              | Aluminum alloy               |
| 8   | Hexagon socket head set bore       | Carbon steel                 |
| 9   | Guide pin/flat key                 | Carbon steel                 |
| 10  | Deep-groove bearing                | Subassembly                  |
| 11  | Bearing retainer                   | Aluminum alloy               |
| 12  | Deep-groove bearing/Needle bearing | Subassembly                  |
| 13  | Back cover                         | Aluminum alloy               |
| 14  | Steel ball                         | Stainless steel              |
| 15  | Piston seal                        | NBR                          |
| 16  | Wear ring                          | Wear resistant material      |
| 17  | Magnet                             | Rare earths                  |
| 18  | Rack                               | Stainless steel/Carbon steel |
| 19  | Pinion                             | Chrome molybdenum steel      |
| 20  | O-ring                             | NBR                          |
| 21  | Bumper                             | NBR                          |
| 22  | O-ring                             | NBR                          |
| 23  | O-ring                             | NBR                          |
| 24  | Hexagon screw                      | Stainless steel              |
| 25  | Shock absorber                     | Subassembly                  |

### Dimensions

#### HRQ2/3/7

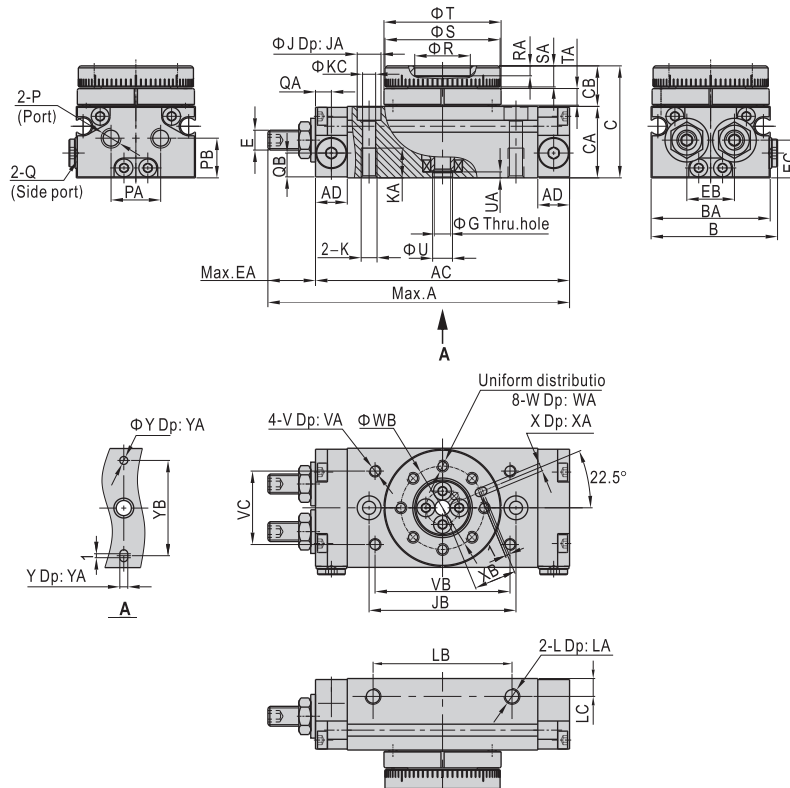

| Type/Item | A    | AC     | AD | B    | BA     | C    | CA     | CB   | E        | EA  | EB    | EC   | G      | J   | JA  | JB   | K      | KA  | KC  | L      | LA | LB   | LC    | P      | PA   |
|-----------|------|--------|----|------|--------|------|--------|------|----------|-----|-------|------|--------|-----|-----|------|--------|-----|-----|--------|----|------|-------|--------|------|
| 2         | 76   | 64     | 8  | 32   | 30     | 28   | 18     | 10   | M5×0.8   | 12  | 12    | 9.5  | 4      | 6   | 3.5 | 37   | M4×0.7 | 7.5 | 3.5 | M4×0.7 | 4  | 35   | 4.5   | M5×0.8 | 12.5 |
| 3         | 82   | 70     | 8  | 36.5 | 34.5   | 30.5 | 20.5   | 10   | M5×0.8   | 12  | 15.5  | 10.5 | 5      | 7.5 | 4.5 | 43   | M5×0.8 | 8.5 | 4.5 | M4×0.7 | 4  | 40   | 4.5   | M5×0.8 | 15.5 |
| 7         | 94.5 | 79.5   | 8  | 43   | 41     | 34.5 | 23     | 11.5 | M6×1.0   | 15  | 18.5  | 12   | 6      | 7.5 | 4.5 | 50   | M5×0.8 | 8.5 | 4.5 | M5×0.8 | 5  | 50   | 5     | M5×0.8 | 18.5 |
| Type/Item | PB   | Q      | QA | QB   | R      | RA   | S      | SA   | T        | TA  | U     | UA   | V      | VA  | VB  | VC   | W      | WA  | WB  | X      | XA | XB   | Y     | YA     | YB   |
| 2         | 10   | M5×0.8 | 4  | 6    | 14(H9) | 2.5  | 29(h9) | 5.5  | 29.5(h9) | 4   | 5(H9) | 1.5  | M3×0.5 | 3.5 | 34  | 18.5 | M3×0.5 | 5.5 | 21  | 2(H9)  | 2  | 10.5 | 2(H9) | 2      | 24   |
| 3         | 12   | M5×0.8 | 4  | 7.5  | 17(H9) | 2.5  | 33(h9) | 5.5  | 34(h9)   | 4   | 6(H9) | 1.5  | M3×0.5 | 3.5 | 38  | 23   | M3×0.5 | 5.5 | 25  | 2(H9)  | 2  | 12.5 | 2(H9) | 2      | 28   |
| 7         | 14   | M5×0.8 | 4  | 9    | 20(H9) | 3    | 39(h9) | 6.5  | 40(h9)   | 4.5 | 7(H9) | 1.5  | M4×0.7 | 4.5 | 45  | 30   | M4×0.7 | 6.5 | 29  | 3(H9)  | 3  | 14.5 | 3(H9) | 3      | 32   |

#### HRQ10~50

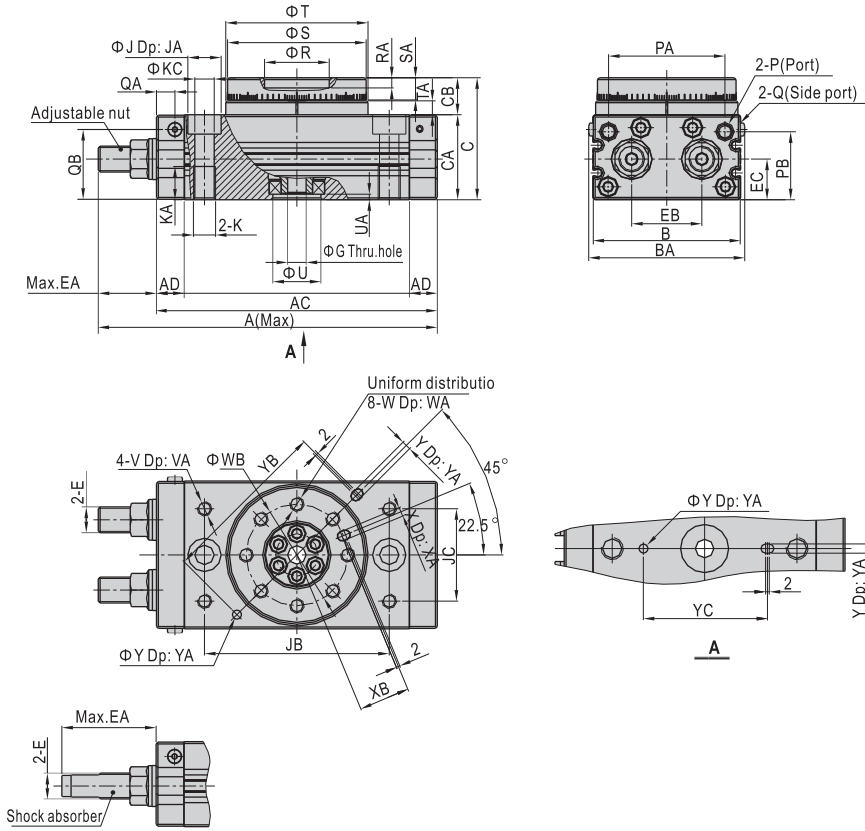

HRQ□-A( With internal shock absorber)

| Type\Item | A(With internal shock absorber) | A(With adjustment bolt) | AC  | AD   | B  | BA | C  | CA | CB | E         | EA(With internal shock absorber) | EA(With adjustment bolt) |
|-----------|---------------------------------|-------------------------|-----|------|----|----|----|----|----|-----------|----------------------------------|--------------------------|
| 10        | 123                             | 112                     | 92  | 9.5  | 50 | 54 | 47 | 34 | 13 | M10 × 1.0 | 31                               | 20                       |
| 20        | 169                             | 145.3                   | 117 | 11   | 65 | 69 | 54 | 37 | 17 | M12 × 1.0 | 52                               | 28.3                     |
| 30        | 178.5                           | 154.5                   | 127 | 11.5 | 70 | 74 | 57 | 40 | 17 | M12 × 1.0 | 51.5                             | 27.5                     |
| 50        | 212                             | 185.9                   | 152 | 15   | 80 | 84 | 66 | 46 | 20 | M14 × 1.5 | 60                               | 33.9                     |

| Type\Item | EB   | EC   | G  | J    | JA  | JB  | JC | K          | KA | KC   | P        | PA   | PB | Q        | QA  | QB | R      | RA  | S      | SA |
|-----------|------|------|----|------|-----|-----|----|------------|----|------|----------|------|----|----------|-----|----|--------|-----|--------|----|
| 10        | 20.5 | 14   | 5  | 11   | 6.5 | 60  | 27 | M8 × 1.25  | 12 | 6.5  | M5 × 0.8 | 34.5 | 28 | M5 × 0.8 | 4.5 | 29 | 20(H9) | 4.5 | 45(h9) | 8  |
| 20        | 27.5 | 16   | 9  | 14   | 8.5 | 76  | 34 | M10 × 1.5  | 15 | 8.5  | M5 × 0.8 | 47   | 30 | M5 × 0.8 | 6   | 30 | 28(H9) | 6.5 | 60(h9) | 10 |
| 30        | 29   | 18.5 | 9  | 14   | 8.5 | 84  | 37 | M10 × 1.5  | 15 | 8.5  | 1/8"     | 50   | 32 | M5 × 0.8 | 6.5 | 34 | 32(H9) | 5   | 65(h9) | 10 |
| 50        | 38   | 22   | 10 | 17.5 | 12  | 100 | 50 | M12 × 1.75 | 18 | 10.5 | 1/8"     | 63   | 38 | M5 × 0.8 | 10  | 38 | 35(H9) | 5.5 | 75(h9) | 12 |

| Type\Item | T      | TA  | U      | UA  | V         | VA | W         | WA | WB | X     | XA  | XB   | Y     | YA  | YB | YC |
|-----------|--------|-----|--------|-----|-----------|----|-----------|----|----|-------|-----|------|-------|-----|----|----|
| 10        | 46(h9) | 4.5 | 15(H9) | 3   | M5 × 0.8  | 8  | M5 × 0.8  | 8  | 32 | 3(H9) | 3.5 | 16   | 3(H9) | 3.5 | 56 | 40 |
| 20        | 61(h9) | 6.5 | 17(H9) | 2.5 | M6 × 1.0  | 8  | M6 × 1.0  | 10 | 43 | 4(H9) | 4.5 | 21.5 | 4(H9) | 4.5 | 74 | 50 |
| 30        | 67(h9) | 6.5 | 22(H9) | 3   | M6 × 1.0  | 8  | M6 × 1.0  | 10 | 48 | 4(H9) | 5   | 24   | 4(H9) | 4.5 | 80 | 58 |
| 50        | 77(h9) | 7.5 | 26(H9) | 3   | M8 × 1.25 | 8  | M8 × 1.25 | 12 | 55 | 5(H9) | 6   | 27.5 | 5(H9) | 5.5 | 92 | 68 |

### HRQ70~200

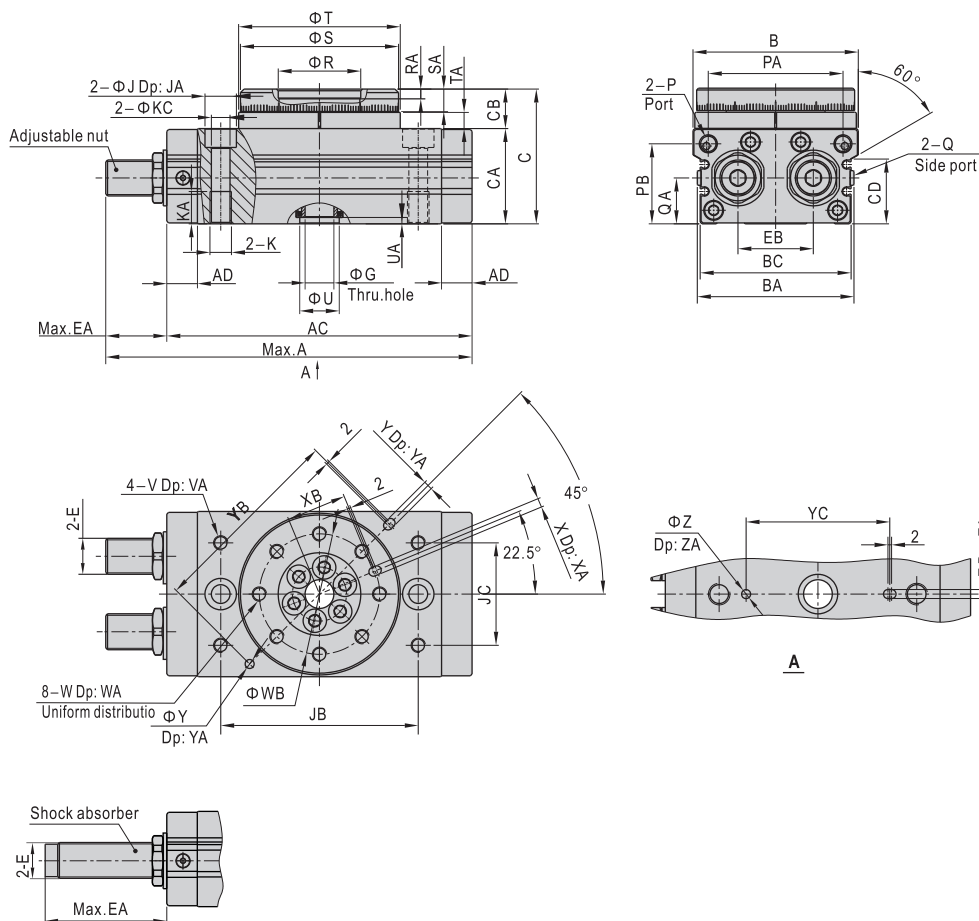

HRQ□-A (With internal shock absorber)

| Type/Item | A(With adjustment bolt) | A(With internal shock absorber) | AC  | AD | B   | BA  | BC  | C   | CA | CB | CD | E         | EA(With adjustment bolt) |
|-----------|-------------------------|---------------------------------|-----|----|-----|-----|-----|-----|----|----|----|-----------|--------------------------|
| 70        | 206.8                   | 244                             | 170 | 17 | 92  | 88  | 84  | 75  | 53 | 22 | 36 | M20 × 1.5 | 36.8                     |
| 100       | 225.7                   | 263                             | 189 | 17 | 102 | 99  | 95  | 86  | 59 | 27 | 42 | M20 × 1.5 | 36.7                     |
| 200       | 279.5                   | 316.5                           | 240 | 24 | 120 | 117 | 113 | 106 | 74 | 32 | 57 | M27 × 1.5 | 39.5                     |

| Type/Item | EA(With internal shock absorber) | EB | G  | J    | JA   | JB  | JC | K          | KA | KC   | P    | PA  | PB   | Q        | QA   | R      | RA | S       | SA   |
|-----------|----------------------------------|----|----|------|------|-----|----|------------|----|------|------|-----|------|----------|------|--------|----|---------|------|
| 70        | 74                               | 42 | 16 | 17.5 | 12   | 110 | 57 | M12 × 1.75 | 18 | 10.5 | 1/8" | 75  | 44.5 | M5 × 0.8 | 25.5 | 46(H9) | 5  | 88(h9)  | 12.5 |
| 100       | 74                               | 50 | 19 | 17.5 | 12   | 130 | 66 | M12 × 1.75 | 18 | 10.5 | 1/8" | 85  | 50.5 | M5 × 0.8 | 29.5 | 56(H9) | 6  | 98(h9)  | 14.5 |
| 200       | 76.5                             | 60 | 24 | 20   | 12.5 | 150 | 80 | M16 × 2.0  | 25 | 14   | 1/8" | 103 | 63   | M5 × 0.8 | 36.5 | 64(H9) | 9  | 116(h9) | 16.5 |

| Type/Item | T       | TA | U      | UA  | V          | VA | W          | WA   | WB | X     | XA  | XB   | Y     | YA  | YB  | YC  | Z     | ZA  |
|-----------|---------|----|--------|-----|------------|----|------------|------|----|-------|-----|------|-------|-----|-----|-----|-------|-----|
| 70        | 90(h9)  | 9  | 22(H9) | 3.5 | M8 × 1.25  | 10 | M8 × 1.25  | 12.5 | 67 | 5(H9) | 5.5 | 33.5 | 5(H9) | 3.5 | 110 | 80  | 5(H9) | 3.5 |
| 100       | 100(h9) | 12 | 24(H9) | 3.5 | M8 × 1.25  | 10 | M10 × 1.5  | 14.5 | 77 | 6(H9) | 6.5 | 38.5 | 6(H9) | 4.5 | 120 | 100 | 6(H9) | 4.5 |
| 200       | 118(h9) | 15 | 32(H9) | 5.5 | M12 × 1.75 | 13 | M12 × 1.75 | 16.5 | 90 | 8(H9) | 8.5 | 45   | 8(H9) | 4.5 | 140 | 110 | 8(H9) | 6.5 |



**How to select product**

- Determine the following working conditions according to the actual situation:
  - 1.1) Rotation angle  $\theta$ : The actual rotation angle must be within the maximum allowed range of rotation angle of cylinder.
  - 1.2) Rotation time  $t$ : The rotation time must be within the maximum allowed range of rotation time of cylinder.
  - 1.3) Installation position of cylinder: Allow enough installation space, so as to ensure leaving adequate space for rotation of cylinder and workpieces.
  - 1.4) Determination of loading mass and loading shape.

|                                |   |
|--------------------------------|---|
| $T = K \times I \times \omega$ | T: Necessary torque required for loading rotation (N.m) |
| $\omega = \frac{2\theta}{t^2}$ | K: Coefficient of allowance, K is defined as 5          |
|                                | I: Moment of inertia (kg.m <sup>2</sup> )               |
|                                | $\omega$ : Angular acceleration (rad/s <sup>2</sup> )   |
|                                | $\theta$ : Rotation Angle (rad)                         |
|                                | t: Rotation time (s)                                    |

2. Calculation of necessary torque needed when loading rotation (T(N.m)):

Calculate the necessary moment required for loading rotation according to the formula below, and combine with the torque diagram of actual effect, to choose pneumatic cylinder with suitable torque output.

2.1) Calculation method of moment of inertia in different conditions

| Diagram | Description   | Calculation formula of moment of inertia  | Rotation radius                   | Diagram | Description  | Calculation formula of moment of inertia   | Rotation radius        |
|---------|---|---|-----------------------------------|---------|--|--|------------------------|
|         | d: Diameter (m)<br>m: Mass (kg)   | $I = \frac{md^2}{8}$  | $\frac{d^2}{8}$                   |         | a: Sheet length (m)<br>b: Length of side (m)<br>m: Mass (kg)   | $I = \frac{m(a^2+b^2)}{12}$  | $\frac{a^2+b^2}{12}$   |
|         |   | Note: no special installation direction   |                                   |         |  | Note: no special installation direction  |                        |
|         | d <sub>1</sub> : Diameter (m)<br>d <sub>2</sub> : Diameter (m)<br>m <sub>1</sub> : d <sub>1</sub> Mass (kg)<br>m <sub>2</sub> : d <sub>2</sub> Mass (kg)                                  | $I = \frac{m_1 d_1^2 + m_2 d_2^2}{8}$   | $\frac{d_1^2 + d_2^2}{8}$         |         | a: Sheet length (m)<br>m: Mass (kg)  | $I = \frac{ma^2}{12}$  | $\frac{a^2}{12}$       |
|         |   | Note: compare d <sub>1</sub> with d <sub>2</sub> , disregard d <sub>1</sub> if d <sub>1</sub> is extremely tiny     |                                   |         |  | Note: no special installation direction  |                        |
|         | d: Diameter (m)<br>m: Mass (kg)   | $I = \frac{md^2}{16}$   | $\frac{d^2}{16}$                  |         | a: Sheet length (m)<br>m: Mass (kg)  | $I = \frac{ma^2}{3}$   | $\frac{a^2}{3}$        |
|         |   | Note: no special installation direction   |                                   |         |  | Note:<br>1. horizontal installation.<br>2. pay attention to the change of movement time when vertical installation.  |                        |
|         | r: Radius (m)<br>m: Mass (kg)   | $I = \frac{2mr^2}{5}$   | $\frac{2r^2}{5}$                  |         | a: Sheet length (m)<br>b: Distance between the rotation axis and the gravity center of loading (m)<br>m: Mass (kg)   | $I = \frac{ma^2}{12} + mb^2$   | $\frac{a^2}{12} + b^2$ |
|         |   | Note: no special installation direction   |                                   |         |  | Note: the cuboids are same too.  |                        |
|         | a <sub>1</sub> : Length of stick (m)<br>a <sub>2</sub> : Length of stick (m)<br>m <sub>1</sub> : a <sub>1</sub> Mass (kg)<br>m <sub>2</sub> : a <sub>2</sub> Mass (kg)                    | $I = \frac{m_1 a_1^2 + m_2 a_2^2}{3}$   | $\frac{a_1^2 + a_2^2}{3}$         |         | a: Tooth number of gear<br>b: Tooth number of loading gear   | $I_a = (\frac{a}{b})^2 I_b$  |                        |
|         |   | Note:<br>1. horizontal installation.<br>2. pay attention to the change of movement time when vertical installation. |                                   |         |  |  |                        |
|         | a <sub>1</sub> : Sheet length (m)<br>a <sub>2</sub> : Sheet length (m)<br>b: Length of side (m)<br>m <sub>1</sub> : a <sub>1</sub> Mass (kg)<br>m <sub>2</sub> : a <sub>2</sub> Mass (kg) | $I = \frac{m_1(4a_1^2+b^2) + m_2(4a_2^2+b^2)}{12}$  | $\frac{2a_1^2 + 2a_2^2 + b^2}{6}$ |         | a <sub>1</sub> : Vertical distance between the rotation axis and the concentrated loading (m)<br>a <sub>2</sub> : Length of arm (m)<br>m <sub>1</sub> : Mass of concentrated loading (kg)<br>m <sub>2</sub> : Mass of arm (kg) | $I = m_1 a_1^2 + \frac{m_2 a_2^2}{3} + m_2 K$  |                        |
|         |   | Note:<br>1. horizontal installation.<br>2. pay attention to the change of movement time when vertical installation. |                                   |         |  | Note:<br>1. horizontal installation.<br>2. compared with m, disregard if m is extremely tiny.<br>3. calculate K according to the shape of concentrated loading row by row. For example, when the loading is spheroid, K=2r <sup>2</sup> /5 |                        |

3. Calculation of maximum movement energy E<sub>max</sub> (J):

Calculate the maximum movement energy E<sub>max</sub> according to the formula below, and make sure that the maximum movement energy is within allowed energy range of the chosen pneumatic cylinder, excessive large movement energy would lead to damage of inner parts, please choose rotation cylinder attached with shock absorber when the movement energy is fairly large.

$$E_{max} = \frac{1}{2} I \omega_{max}^2 \quad \omega_{max} = \frac{2\theta}{t} \quad \omega_{max}: \text{Maximal angular velocity (rad/s)}$$

4. Calculation of loading rate

Calculate the loading rate according to the formula below, and the loading rate must not be more than 1.

$$\text{Loading rate} = \frac{W_s}{\text{Maximal allowed axial loading}} + \frac{W_r}{\text{Maximal allowed radial loading}} + \frac{M}{\text{Maximal allowed bending moment of working platform}} \leq 1$$

W<sub>s</sub>: Actual axial loading    W<sub>r</sub>: Actual radial loading    M: Actual loaded bending moment of working platform

5. Determination method

It could be used only when the chosen pneumatic cylinder must meet the requirements of article 2, 3 and 4 simultaneously.

### Installation and application

#### 1. Rotation Direction and Rotation Angle

##### 1.1) Rotation Direction

**HRQ2/3/7**

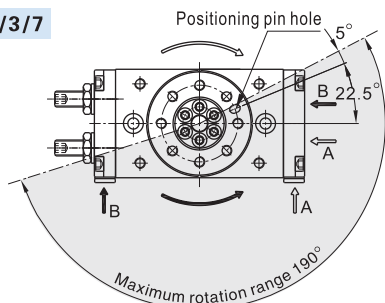

**HRQ10~200**

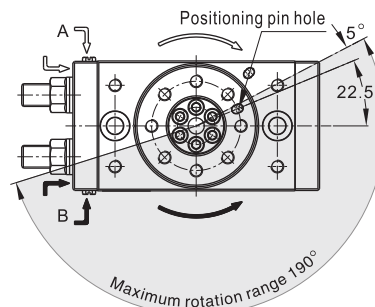

A) By adjusting the adjustment bolt, the rotation end can be set within the range shown in the up drawing: Maximum rotation is 190° ;  
 B) The rotary table turns in the clockwise direction when the A port is pressurized, and in the counter-clockwise direction when the B port is pressurized.

##### 1.2) Rotation Range Example(90° Rotation)

**HRQ2/3/7**

Adjustment amount by adjustment bolt B

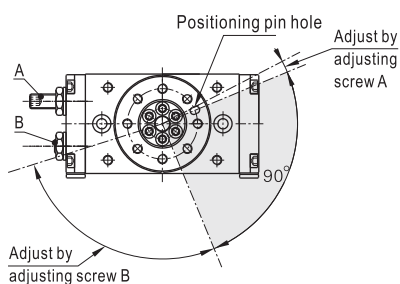

**HRQ10~200**

Adjustment amount by adjustment bolt B

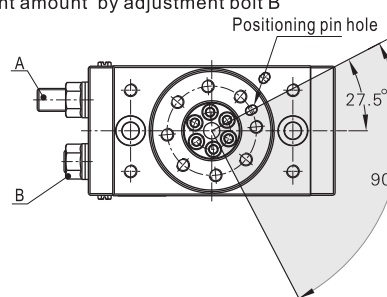

Adjustment amount by adjustment bolt A

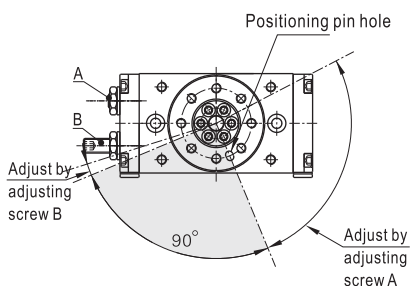

Adjustment amount by adjustment bolt A

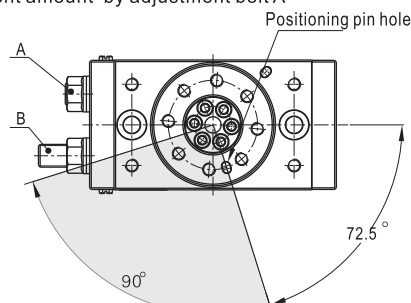

Adjustment amount by adjustment bolt A, B

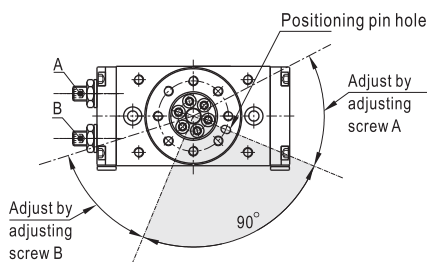

Adjustment amount by adjustment bolt A, B

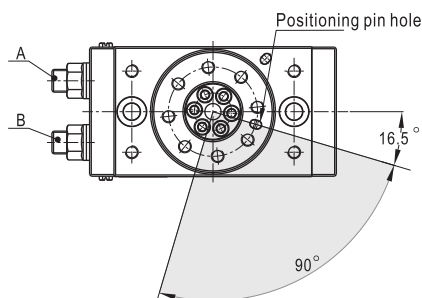

1.3) The rotation angle can also be set on a type with internal absorber.

| Model | Adjustment angle per rotation of angle(adjustment screw) | Model  | Adjustment angle per rotation of angle(adjustment screw or shock absorber) |
|-------|--|--------|--|
| HRQ2  | 11.5°  | HRQ10  | 10.2°  |
| HRQ3  | 10.9°  | HRQ20  | 6.5°   |
| HRQ7  | 10.2°  | HRQ30  | 6.5°   |
|       |  | HRQ50  | 8.2°   |
|       |  | HRQ70  | 7.0°   |
|       |  | HRQ100 | 6.1°   |
|       |  | HRQ200 | 4.9°   |

2. The range of rotation angle has been adjusted to the maximum in the factory, please do not enlarge the rotation angle any more.
3. The movement energy should not exceed the allowed maximum energy, or the inner parts will be damaged.
4. The rotary parts need no lubrication.
5. Series HRQ is equipped with a rubber bumper or shock absorber. Therefore, perform rotation adjustment in the pressurized condition (minimum operation pressure: 0.1 Mpa or more for adjustment bolt and internal shock absorber types, and 0.2 MPa or more for external shock absorber type.)
6. Refer to the table below for tightening torques of the shock absorber setting nut.

| Shock absorber size | Max. tightening torque(Nm) |
|---------------------|----------------------------|
| M10                 | 3.5                        |
| M12                 | 8.0                        |
| M14                 | 11.0                       |
| M20                 | 24.0                       |
| M27                 | 63.0                       |

7. Never loosen the bottom screw of the shock absorber. (It is not an adjustment screw.) That may cause oil leakage.
8. Shock absorbers are consumable parts.  
When a decrease in energy absorption capacity is noticed, it must be replaced.

| Rotary table cylinder | Shock absorber |
|-----------------------|----------------|
| HRQ10                 | ACA1006-A      |
| HRQ20\HRQ30           | ACA1215-A      |
| HRQ50                 | ACA1416-A      |
| HRQ70\HRQ100          | ACA2020-A      |
| HRQ200                | ACA2725-A      |

9. Strictly control run out and parallelism of the dial according to the requirements of the following table.

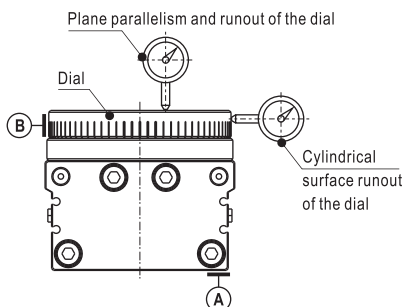

| Items                                  | Specific requirements | Relative datum |
|--|-----------------------|----------------|
| Plane parallelism of the dial          | 0.1                   | A              |
| Plane runout of the dial               | 0.1                   | A              |
| Cylindrical surface runout of the dial | 0.1                   | A              |