

Compendium of RMT Series

With magnet and without magnet are available

Without magnet

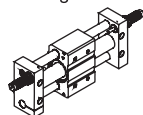

With magnet

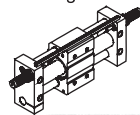

Magnetic design

This magnetic cylinder is basically a pneumatic rodless cylinder featuring a mobile piston fitted with annular magnets.

Two kinds of cushion type

The non adjustable rubber bumpers and the adjustable pneumatic cushioning on both ends of the cylinder ensure the smooth action. If shock absorber be used, the cushioning effect is more perfection.

Double guides

Double guides ensure high precision and can endure proper side load or prejudicial load.

Five bore size are available

Bore size: 16, 20, 25, 32, 40

It is compact in space

Can be mounted from top and bottom.

Superiority of airproof

It is dust-proof as the isolation between the carriage and piston.

Top bolt mounting

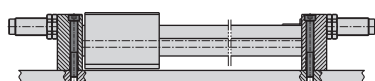
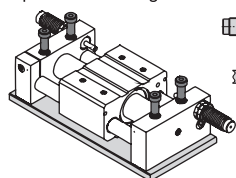

Bottom bolt mounting

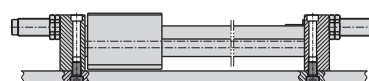
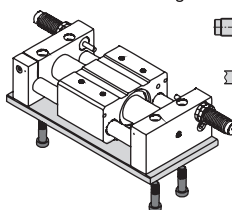

Installation and application

1. Dirty substances in the pipe must be eliminated before cylinder is connected with pipeline to prevent the entrance of impurities into the cylinder.
2. The medium used by cylinder shall be filtered to 40µm or below.
3. Anti-freezing measure shall be adopted under low temperature environment to prevent moisture freezing.
4. If the cylinder is dismantled and stored for a long time, pay attention to conduct anti-rust treatment to the surface.
Anti-dust caps shall be added in air inlet and outlet ports.

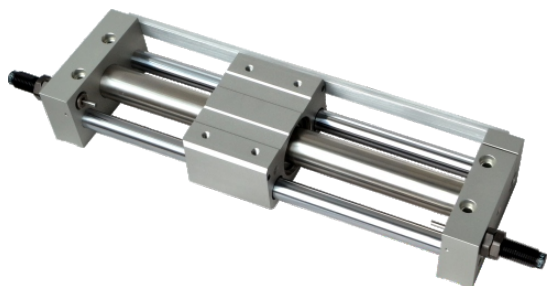

Specification

Bore size (mm)	16	20	25	32	40
Acting type	Double acting				
Fluid	Air (to be filtered by 40µm filter element)				
Operating pressure	0.2~0.7MPa(30~100psi(2.0~7bar)) 0.25~0.7MPa(36~100psi(2.5~7bar))				
Proof pressure	1.2MPa(175psi)(12.0bar)				
Temperature □	-20~70				
Speed range mm/s	50~400				
Stroke tolerance mm	0~250 ^{+1.0} / ₀ 251~1000 ^{+1.5} / ₀ 1001~ ^{+2.0} / ₀				
Cushion type	Fixed cushion Shock absorber(Available)				
Safe holding force N	140		220	345	560 880
Port size [Note1]	M5×0.8		1/8"		1/4"

[Note1] PT thread, G thread and NPT thread are available.
Add) Refer to P353 for detail of sensor switch.

Symbol

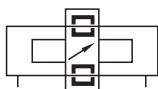

Product feature

1. This magnetic cylinder is basically a pneumatic rodless cylinder featuring a mobile piston fitted with annular magnets. The mobile carriage is also equipped with magnets to provide magnetic coupling (carriage/piston). The carriage slide freely along the main tube.
2. It is dust-proof as the isolation between the carriage and piston.
3. It is compact in space.
4. The non adjustable rubber bumpers and the adjustable pneumatic cushioning on both ends of the cylinder ensure the smooth action. If shock absorber be used, the cushioning effect is more perfection.
5. Double guides ensure high precision and can endure proper side load or prejudicial load.

Stroke

Bore size (mm)	Standard stroke (mm)	Max.std stroke
16	50 100 150 200 250 300 350 400 450 500	750
20	50 100 150 200 250 300 350 400 450 500 600 700 750 800	1000
25	50 100 150 200 250 300 350 400 450 500 600 700 750 800	1500
32	50 100 150 200 250 300 350 400 450 500 600 700 750 800	1500
40	50 100 150 200 250 300 350 400 450 500 600 700 750 800 900 1000	1500

[Note] Consult us for non-standard stroke.

Ordering code

RMT 20 × 100 S □ □

① ② ③ ④ ⑤ ⑥

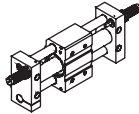
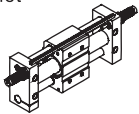
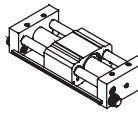
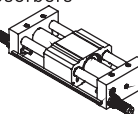
① Model	② Bore size	③ Stroke	④ Magnet	⑤ Cushion type	⑥ Thread type [Note1]
RMT: Rodless magnetic cylinder (With guide)	16 20 25 32 40	Refer to stroke table for details	Blank: Without magnet  S: With magnet 	Blank: With two adjustable nuts  A: With two shock absorbers 	Blank: PT G: G T: NPT

[Note1] Blank on thread code means metric M thread. There is only metric thread for Φ16. If G or NPT thread is needed, please comment.

Inner structure and material of major parts

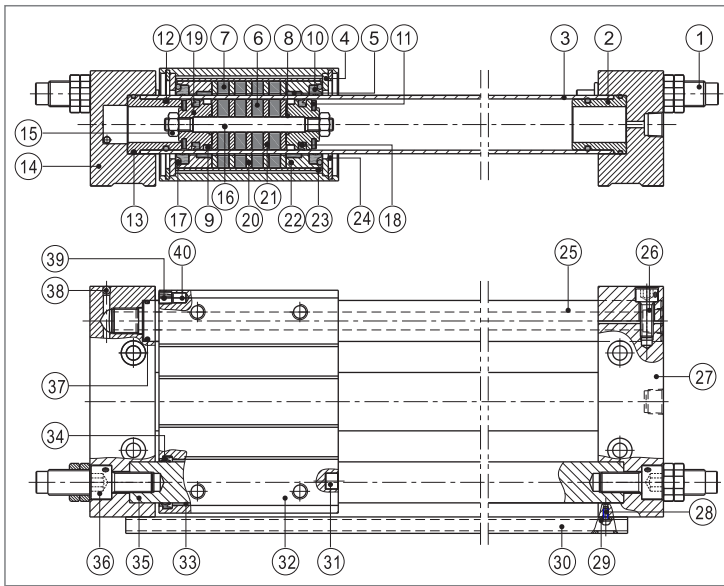

NO.	Item	Material	NO.	Item	Material
1	Shock absorber	Combination	21	Magnet washer	Carbon steel
2	Washer cover	Aluminum alloy	22	End cover	Aluminum alloy
3	Stainless steel barrel	Stainless steel	23	Mobility iron	Aluminum alloy
4	Washer	Carbon steel	24	C clip	Spring steel
5	Wearing ring	Wear resistant material	25	Guide I	Carbon steel
6	Magnet	Rare-earth material	26	Countersink screw	Carbon steel
7	Magnet	Rare-earth material	27	Fixing plate	Aluminum alloy
8	O-ring	NBR	28	Screw	Carbon steel
9	Wear ring	Wear resistant material	29	Spring washer	Spring steel
10	Scraping dust ring	Plastics	30	Rail	Aluminum alloy
11	Bumper	NBR	31	Bumper block	Stainless steel
12	O-ring	NBR	32	Barrel	Aluminum alloy
13	O-ring	NBR	33	Bushing	Bronze+Fill lubricant
14	Fixing plate	Aluminum alloy	34	Gasket	TPU
15	Nut	SS41	35	Guide II	Carbon steel
16	Joint pole	Stainless steel	36	Countersink screw	Carbon steel
17	O-ring	NBR	37	O-ring	NBR
18	Piston seal	TPU	38	Steel ball	Stainless steel
19	Magnet	Aluminum alloy	39	Location washer	NBR
20	Magnet washer	Carbon steel	40	Magnet	Rare-earth material

Installation and application

1. How to determine load

1.1) The maxi load to move must be less than the theoretical holding force.

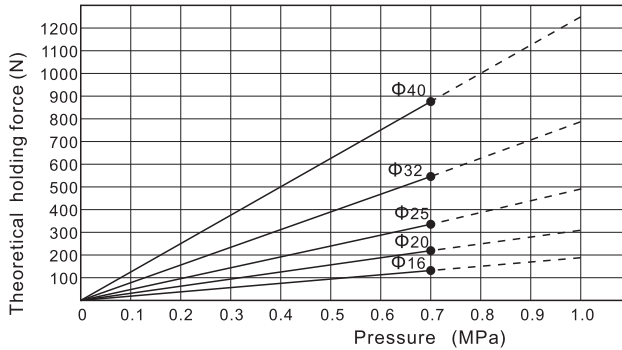

1.2) The relation between loading and stroke as below (Loading center and slide table center must be superposition)

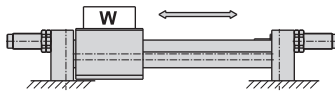

Bore size	Max.Load W(kg)	Stroke scope
16	5	~300mm
20	6	~500mm
25	8	~500mm
32	10	~600mm
40	16	~600mm

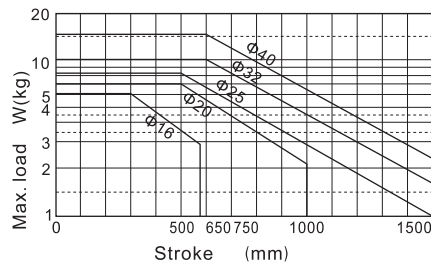

2. About shock absorber

- 2.1) Shock absorbers are consumable parts. When a decrease in energy absorption capacity is noticed, it must be replaced. Refer to the table below for shock absorber type.
- 2.2) Never loosen the bottom screw of the shock absorber. (It is not an adjustment screw.) That may cause oil leakage.
- 2.3) Refer to the table below for tightening torques of the shock absorber setting nut.

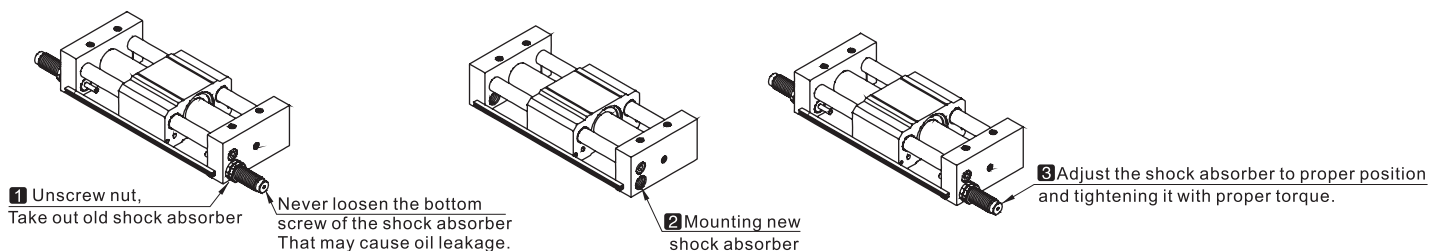

Cylinder model	RMT16	RMT20	RMT25	RMT32	RMT40
Shock absorber type	ACA1006-A	ACA1007-1N	ACA1412-1N	ACA2020-1N	ACA2020-1N
Tightening torque(Nm)	1.67	1.67	3.14	10.80	10.80

3. About sensor switch

- 3.1) Sensor switch only can be used for the cylinder with magnet . The magnet located the four corner of body's(refer below) . The cylinder with magnet have both group mounting hole for mounting rail. please refer to below for ordering sensor switch, mounting it into the rsil's groove, adjusting it to proper position, tightening it with proper torque.

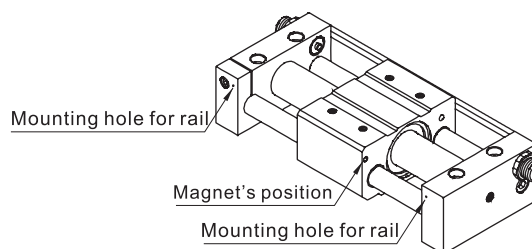
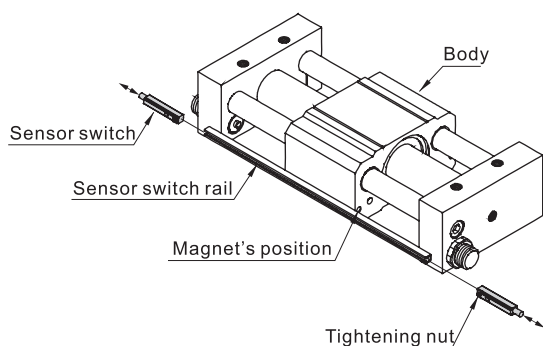

Cylinder model	RMT16	RMT20	RMT25	RMT32	RMT40
Sensor switch	CMSG、DMSG(S)				

Dimensions

RMT-A

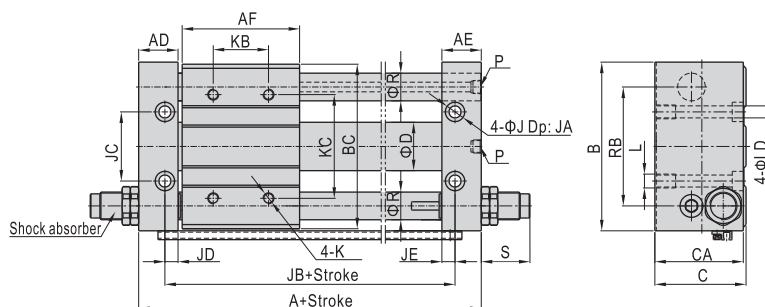

RMT

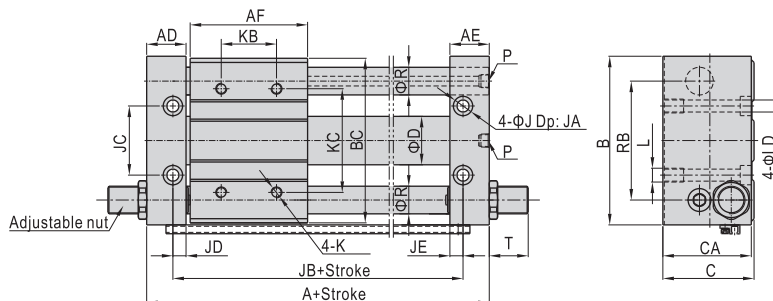

Bore size/Item	A	AD	AE	AF	B	BC	C	CA	D	J	JA	JB	JC	JD	JE	K	KB	KC	L	LD	P	R	RB	S	T
16	107	22.5	22.5	60	75	72	40	39	18	9.5	5	75	30	6.5	6.5	M5×0.8Dp:10	30	50	M6×1.0Dp:9.5	5.5	M5×0.8	12	52	18.5	13.5
20	124	25.5	25.5	70	90	87	46	45	22.8	9.5	5	90	38	8.5	8.5	M6×1.0Dp:10	40	70	M6×1.0Dp:9.5	5.5	1/8"	16	63	22.5	10
25	124	25.5	25.5	70	100	97	54	53	27.8	11	6.5	90	42	8.5	8.5	M6×1.0Dp:10	40	70	M8×1.25Dp:10	7	1/8"	16	70	40.5	15
32	148	28.5	28.5	85	122	119	66	64	35	14	8	110	50	9.5	9.5	M8×1.25Dp:12	40	75	M10×1.5Dp:15	8.5	1/8"	20	86	57.5	16
40	170	35.5	35.5	95	145	142	76	74	43	14	8	120	64	10.5	10.5	M8×1.25Dp:12	65	105	M10×1.5Dp:15	8.5	1/4"	25	105	50.5	10

Compendium of RMTL Series

With magnet and without magnet are available

Without magnet

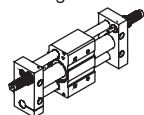

With magnet

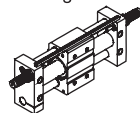

Magnetic design

This magnetic cylinder is basically a pneumatic rodless cylinder featuring a mobile piston fitted with annular magnets.

Two kinds of cushion type

The non adjustable rubber bumpers and the adjustable pneumatic cushioning on both ends of the cylinder ensure the smooth action. If shock absorber be used, the cushioning effect is more perfection.

Six bore size are available

Bore size: 16, 20, 25, 32, 40

Double guides

Double guides ensure high precision and can endure proper side load or prejudicial load.

It is compact in space

Can be mounted from top and bottom.

Superiority of airproof

It is dust-proof as the isolation between the carriage and piston.

Top bolt mounting

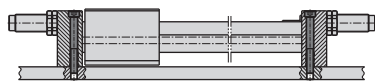
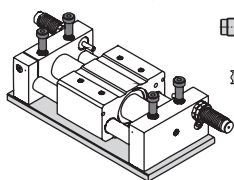

Bottom bolt mounting

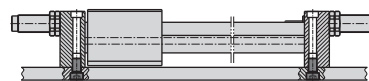
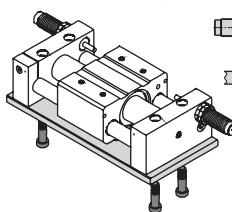

Installation and application

1. Dirty substances in the pipe must be eliminated before cylinder is connected with pipeline to prevent the entrance of impurities into the cylinder.
2. The medium used by cylinder shall be filtered to 40µm or below.
3. Anti-freezing measure shall be adopted under low temperature environment to prevent moisture freezing.
4. If the cylinder is dismantled and stored for a long time, pay attention to conduct anti-rust treatment to the surface.
Anti-dust caps shall be added in air inlet and outlet ports.



Specification

Bore size (mm)	10	16	20	25	32	40
Acting type	Double acting					
Fluid	Air (to be filtered by 40µm filter element)					
Operating pressure	0.2~0.7MPa(30~100psi)(2.0~7bar)					
Proof pressure	1.2MPa(175psi)(12.0bar)					
Temperature °C	-20~70					
Speed range mm/s	50~500					
Stroke tolerance mm	0~250 ^{+1.0} ₀		251~1000 ^{+1.5} ₀		1001~ ^{+2.0} ₀	
Cushion type	Fixed cushion			Shock absorber(Available)		
Safe holding force N	55	140	220	345	560	880
Port size [Note1]	M5×0.8			1/8"		1/4"

[Note1] PT thread, G thread and NPT thread are available.
Add) Refer to P353 for detail of sensor switch.

Symbol

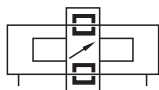

Product feature

1. This magnetic cylinder is basically a pneumatic rodless cylinder featuring a mobile piston fitted with annular magnets. The mobile carriage is also equipped with magnets to provide magnetic coupling (carriage/piston). The carriage slide freely along the main tube.
2. It is dust-proof as the isolation between the carriage and piston.
3. It is compact in space.
4. The non adjustable rubber bumpers and the adjustable pneumatic cushioning on both ends of the cylinder ensure the smooth action. If shock absorber be used, the cushioning effect is more perfection.
5. Double guides ensure high precision and can endure proper side load or prejudicial load.

Stroke

Bore size (mm)	Standard stroke (mm)	Max.std stroke
10	50 100 150 200 250 300	500
16	50 100 150 200 250 300 350 400 450 500	750
20	50 100 150 200 250 300 350 400 450 500 600 700 750 800	1000
25	50 100 150 200 250 300 350 400 450 500 600 700 750 800	1500
32	50 100 150 200 250 300 350 400 450 500 600 700 750 800	1500
40	50 100 150 200 250 300 350 400 450 500 600 700 750 800 900 1000	1500

[Note] Consult us for non-standard stroke.

Ordering code

RM TL 20 × 100 S □ □

① ② ③ ④ ⑤ ⑥

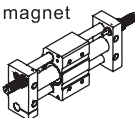
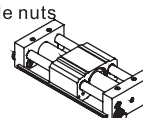
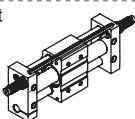
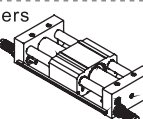
① Model	② Bore size	③ Stroke	④ Magnet	⑤ Cushion type [Note1]	⑥ Thread type
RM TL: Rodless magnetic cylinder (With exactitude guide)	10 16	Refer to stroke table for details	Blank: Without magnet 	Blank: With two adjustable nuts 	Blank: M5 Blank: PT G: G T: NPT
	20 25 32 40		S: With magnet 	A: With two shock absorbers 	

[Note1] When A type is selected, the two adjustable nuts are added too.

Inner structure and material of major parts

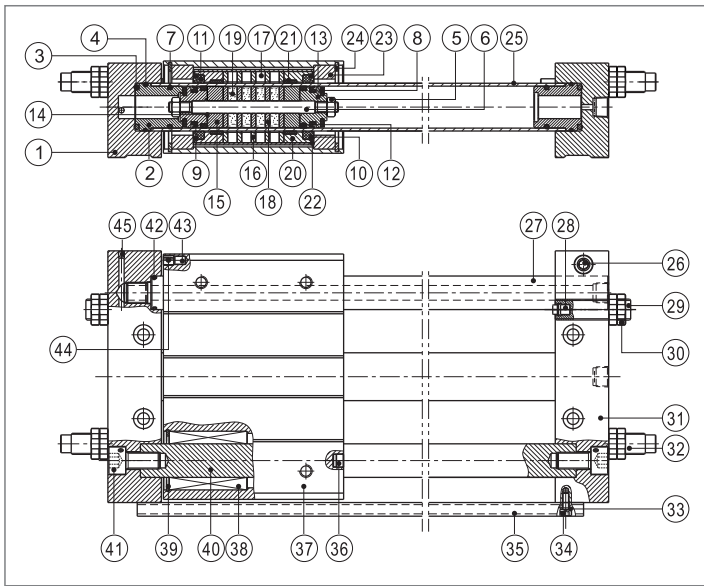

NO.	Item	Material	NO.	Item	Material
1	Fixing plate	Aluminum alloy	24	C clip	Spring steel
2	Washer cover	Aluminum alloy	25	Barrel	Stainless steel
3	O-ring	NBR	26	Countersink screw	Carbon steel
4	O-ring	NBR	27	Guide I	Carbon steel
5	Nut	Carbon steel	28	Bumper	TPU
6	Joint pole	Stainless steel	29	Adjustable screw	Carbon steel
7	O-ring	NBR	30	Nut	Ss41
8	Bumper	NBR	31	Fixing plate	Aluminum alloy
9	Piston seal	TPU	32	Shock absorber	Combination
10	O-ring	NBR	33	Spring washer	Spring steel
11	Scraping dust ring	Plastics	34	Countersink screw	Carbon steel
12	Wearing ring	Wear resistant material	35	Rail	Aluminum alloy
13	Piston	Aluminum alloy	36	Bumper block	Stainless steel
14	O-ring	NBR	37	Body	Aluminum alloy
15	Piston washer	Aluminum alloy	38	Bushing	
16	Magnet washer	Carbon steel	39	C clip	Spring steel
17	Magnet	Rare-earth material	40	Guide II	Carbon steel
18	Magnet washer	Carbon steel	41	Countersink screw	Carbon steel
19	Magnet	Rare-earth material	42	O-ring	NBR
20	Body cover	Aluminum alloy	43	Magnet	Rare-earth material
21	Wearing ring	Wear resistant material	44	Location washer	NBR
22	Mobility iron	Aluminum alloy	45	Steel ball	Stainless steel
23	Washer	Aluminum alloy			

Installation and application

1. How to determine load

The main load to move must be less than the theoretical holding force.

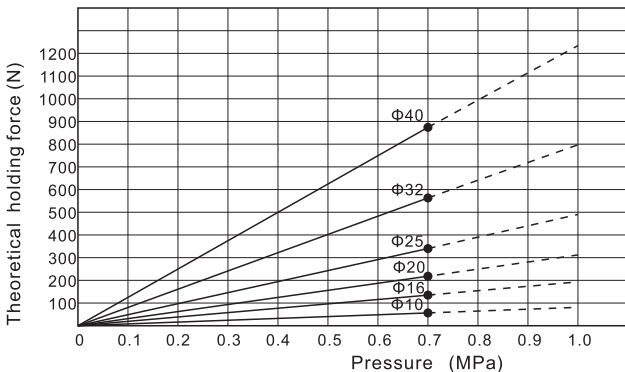

The relation between loading and stroke as below

(Loading center and slide table center must be superposition)

Bore size	Max. Load W(kg)	Stroke scope
10	2.4	~200mm
16	5	~300mm
20	6	~500mm
25	8	~500mm
32	10	~600mm
40	16	~600mm

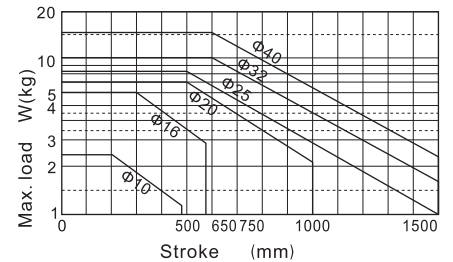

2. About shock absorber

2.1) Shock absorbers are consumable parts. When a decrease in energy absorption capacity is noticed, it must be replaced. Refer to the table below for shock absorber type.

2.2) Never loosen the bottom screw of the shock absorber. (It is not an adjustment screw.) That may cause oil leakage.

2.3) Refer to the table below for tightening torques of the shock absorber setting nut.

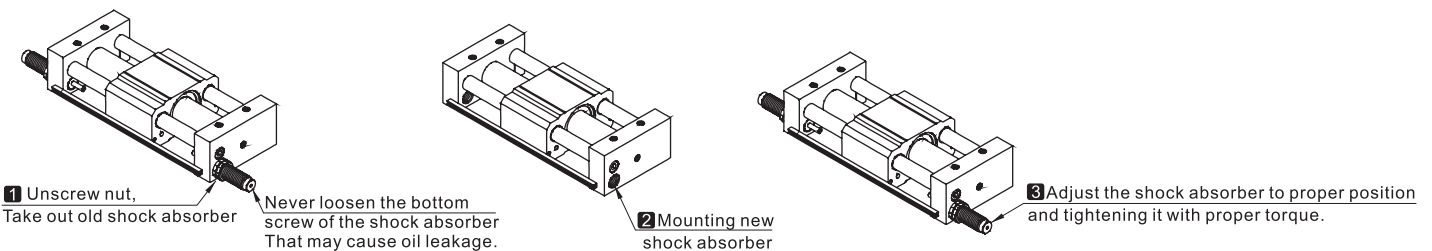

Bore size	10	16	20	25	32	40
Shock absorber type	ACA0806-1N	ACA1006-A	ACA1007-1N	ACA1412-1N	ACA2020-1N	ACA2020-1N
Tightening torque(Nm)	1.67	1.67	1.67	3.14	10.80	10.80

3. About sensor switch

3.1) Sensor switch only can be used for the cylinder with magnet . The magnet located the four corner of body's(refer below) .The cylinder with magnet have both group mounting hole for mounting rail. please refer to below for ordering sensor switch, mounting it into the rail's groove, adjusting it to proper position, tightening it with proper torque.

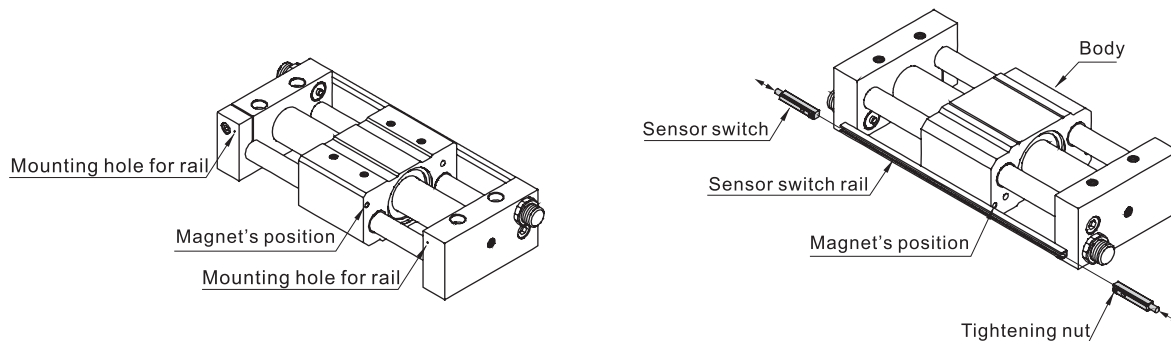

Dimensions

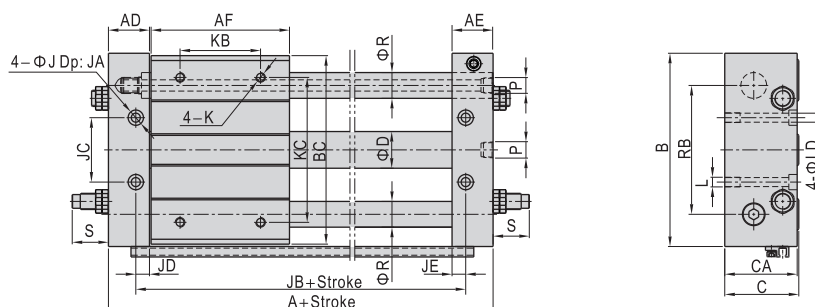

Model	A	AD	AE	AF	B	BC	C	CA	D	J	JA	JB	JC	JD	JE	K	KB	KC	L	LD	P	R	RB	S
RMTL10	111	20.5	20.5	68	80	77	34	33	12	8	4	85	26	7.5	7.5	M4X0.7Dp:8	30	60	M5X0.8Dp:9.5	4.5	M5X0.8	10	52	17.5
RMTL16	122	22.5	22.5	75	95	92	40	39	18	9.5	5	90	30	6.5	6.5	M5X0.8Dp:10	45	70	M6X1.0Dp:9.5	5.5	M5X0.8	12	65	18.5
RMTL20	139	25.5	25.5	86	120	117	46	45	22.8	9.5	5	105	40	8.5	8.5	M6X1.0Dp:10	50	90	M6X1.0Dp:10	5.5	1/8"	16	80	22.5
RMTL25	139	25.5	25.5	86	130	127	54	53	27.8	11	6.5	105	50	8.5	8.5	M6X1.0Dp:10	60	100	M8X1.25Dp:10	7	1/8"	16	90	40.5
RMTL32	159	28.5	28.5	100	160	157	66	64	35	14	8	121	60	9.5	9.5	M8X1.25Dp:12	70	120	M10X1.5Dp:15	8.5	1/8"	20	110	57.5
RMTL40	209	35.5	35.5	136	190	187	78	74	43	14	8	159	84	10.5	10.5	M8X1.25Dp:12	90	140	M10X1.5Dp:15	8.5	1/4"	25	130	50.5